

Aquarius®

LEAD-FREE POTABLE WATER TRANSPORT SOLUTIONS

PRODUCT CATALOGUE



CIN NO: L25200GJ1996PLC029134

Registered & Corporate Office: Astral Poly Technik Limited

207/1, 'Astral House', B/h Rajpath Club, Off S. G. Highway, Ahmedabad - 380059.

Ph: +91-79 6621 2000 | Fax: +91-79 6621 2121 | E-mail: info@astralpipes.com | Website: www.astralpipes.com

For Export Inquiries : export@astralpipes.com



CONTENTS



03

ABOUT ASTRAL

04

INNOVATION &
RECOGNITIONS

05

MARKETING
NETWORK

06

LEADING THE
LEAD-FREE PIPE
MOVEMENT

08

ABOUT AQUARIUS

09

THE DIFFERENCE
BETWEEN
uPVC & PVC

09

PVC - POLYVINYL
CHLORIDE

10

BENEFITS OF ASTRAL
AQUARIUS SYSTEM
OVER OTHER uPVC
SYSTEMS

11

CERTIFICATES
& APPROVALS

12

STANDARDS &
SPECIFICATIONS

13

IMPORTANT FOR
INSTALLERS & USERS

14

KEY
PROPERTIES

15

FIELDS OF
APPLICATIONS

16

PRESSURE PIPES
AND FITTINGS

17

PVC SCHEDULE 40
AND SCHEDULE 80
FITTINGS

18

BASIC SOCKET
DIMENSIONS

19

PRODUCT
RANGE

38

FRICTION LOSS
TABLE

40

EXPANSION AND
CONTRACTION OF
uPVC PIPE

42

JOINT CURING &
SUPPORT SPACING
FOR uPVC PIPE

44

INSTALLATION
PROCEDURE

46

TESTING
PRESSURE SYSTEM

47

UNDERGROUND
INSTALLATION

49

HANDLING
AND STORAGE

50

FREQUENTLY ASKED
QUESTIONS (FAQs)

ASTRAL, INDIA'S PROGRESSIVE PIPE COMPANY

1st TO INTRODUCE CPVC IN INDIA

1st TO INTRODUCE UPVC LEAD FREE PIPES IN INDIA

1st TO INTRODUCE LOW NOISE PP DRAINAGE PIPES IN INDIA

1st TO INTRODUCE FOAMED PVC DRAINAGE PIPES IN INDIA



Established in 1996 with the aim to manufacture best-in-globe plastic piping systems, Astral Pipes fulfils emerging piping needs of millions of houses and adds extra mileage to India's developing real estate fraternity with the hallmark of unbeaten quality and innovative piping solutions. Keeping itself ahead of the technology curve, Astral has always been a front runner in the piping category by bringing innovation and getting rid of old, primitive and ineffective plumbing methods. Bringing CPVC in India, and pioneering in this technology, have set Astral apart and its highest quality enabled it to obtain NSF approval for its CPVC pipes and fittings. Astral went beyond the category codes by launching many industry firsts, like launching India's first lead-free uPVC pipes for plumbing as well as for stream water, just to name a few.

Astral Pipes offers the widest product range across this category when it comes to product applications. Astral Pipes is equipped with production facilities at Santej and Dholka in Gujarat, Hosur in Tamil Nadu, Ghiloth in Rajasthan and Sangli in Maharashtra to manufacture plumbing systems, drainage systems, agriculture systems, fire sprinkler piping systems, industrial piping and electrical conduit pipes with all kinds of necessary fittings.

Astral Pipes' Infrastructure division Rex offers a comprehensive product range including corrugated piping for drainage and cables, polyolefin cable channels, sewage treatment plants, plastic sheathing ducts, suction hoses, and sub-surface drainage systems. This range helps Astral to establish a strong foothold in infrastructure and agriculture sector in the constantly evolving business of piping.

In 2014, Astral forayed into the adhesives category by acquiring UK-based Seal It Services Ltd. and Kanpur based Resinova Chemie Ltd., which manufacture adhesives, sealants and construction chemicals. With five manufacturing facilities now in this business segment, Astral has strengthened its presence in the category and made rapid inroads.

1st TO INTRODUCE LEAD FREE COLUMN PIPES IN INDIA

1st TO INTRODUCE POLYMER BASED INDUSTRIAL PIPING SYSTEM IN INDIA

1st TO INTRODUCE NSF APPROVED SOLVENT CEMENT IN INDIA

1st TO INTRODUCE CPVC PIPING FOR AUTOMATIC FIRE SPRINKLER SYSTEM IN INDIA



PIPING

AGRICULTURE
DRAINAGE INDUSTRIAL
URBAN INFRASTRUCTURE
PLUMBING
FIRE PROTECTION
CONDUIT SURFACE DRAINAGE
ANCILLARY
INSULATION

ADHESIVES

ANAEROBIC ADHESIVES
SILICONE SEALANTS
CONSTRUCTION CHEMICALS
CYANOACRYLATE
PVA
SOLVENT CEMENTS TAPES
POLYMERIC FILLING COMPOUND
EPOXY ADHESIVES & PUTTY
INDUSTRIAL ADHESIVES



MARKETING NETWORK

ASTRAL has a marketing network of more than 800 distributors and 30,000 dealers spread all over India with branch offices at Mumbai, Pune, Delhi, Bengaluru, Chennai, Hyderabad, Jaipur, Lucknow and Kochi. Apart from that ASTRAL has its own warehouses at Bengaluru, Vijaywada, Hyderabad, Delhi, Ghaziabad, Kolhapur, Pune, Nagpur, Indore, Varanasi, Jaipur & Hosur to deliver the material as quick as possible. More than 400 techno marketing professionals and administrative personnel are on the board to coordinate with architects, plumbing contractors and plumbers to utilize the best plumbing techniques and to get the best from the products.

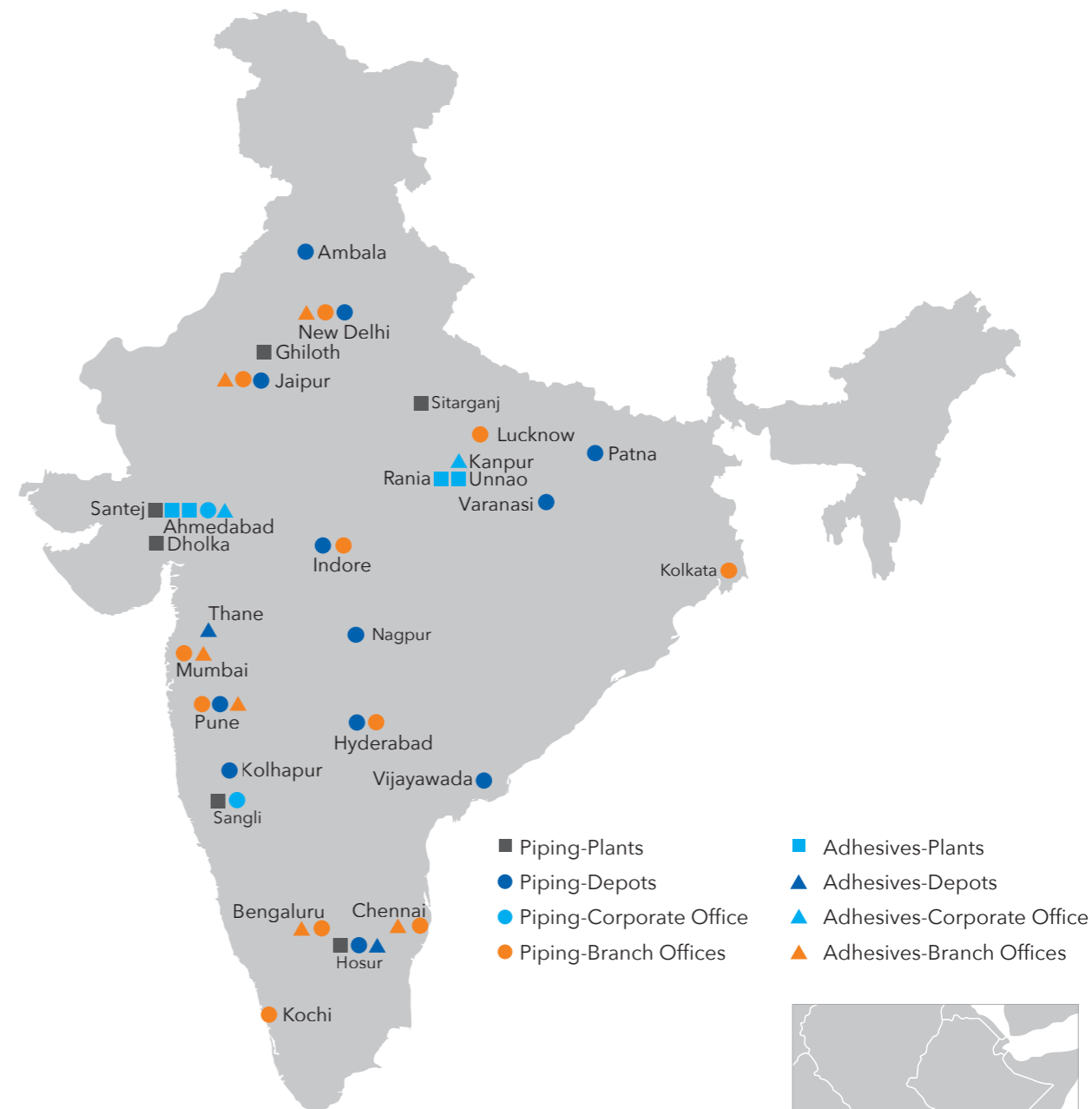

Piping unit
KENYA



INNOVATION & RECOGNITIONS

- First to introduce CPVC piping system in India (1999)
- First to launch lead free uPVC piping system in India (2004)
- Corp Excel- National SME Excellence Award (2006)
- First to get NSF Certification for CPVC piping system in India (2007)
- First to launch lead-free uPVC column pipes in India (2012)
- Enterprising Entrepreneur of the year (2012-13)
- Business Standard Star SME of the year (2013)
- Inc. India Innovative 100 for Smart Innovation under category of 'Technology' (2013)
- India's Most Promising Brand Award (2014)
- Value Creator Award during the first ever Fortune India Next 500 (2015)
- India's Most Trusted Pipe Brand Award (2016 & 2019)
- ET Inspiring Business Leaders of India Award (2016)
- India's Most Attractive Pipe Brand Award (2016)
- Fortune India 500 Company (2016)
- Consumer Validated Superbrands India (2017 & 2019)



LEADING THE LEAD-FREE PIPE MOVEMENT

Lead (Pb on the Periodic Table) is one of the most naturally occurring elements on the planet. With little or no known biological benefit to humans, Lead causes a lot of damage and leads to poisoning when imbibed.



The world over, Lead-free piping is the way forward to transport potable water. Something we've been doing at Astral Pipes for over many years now. Our lead-free pipes have exceeded all quality benchmarks and continue to be one of our bestselling products.

The lead can easily leach or dissolve into the water from transportation pipes and can be fatal. High blood lead levels in children can cause consequences which may be irreversible including learning disabilities, behavioural problems and mental retardation.

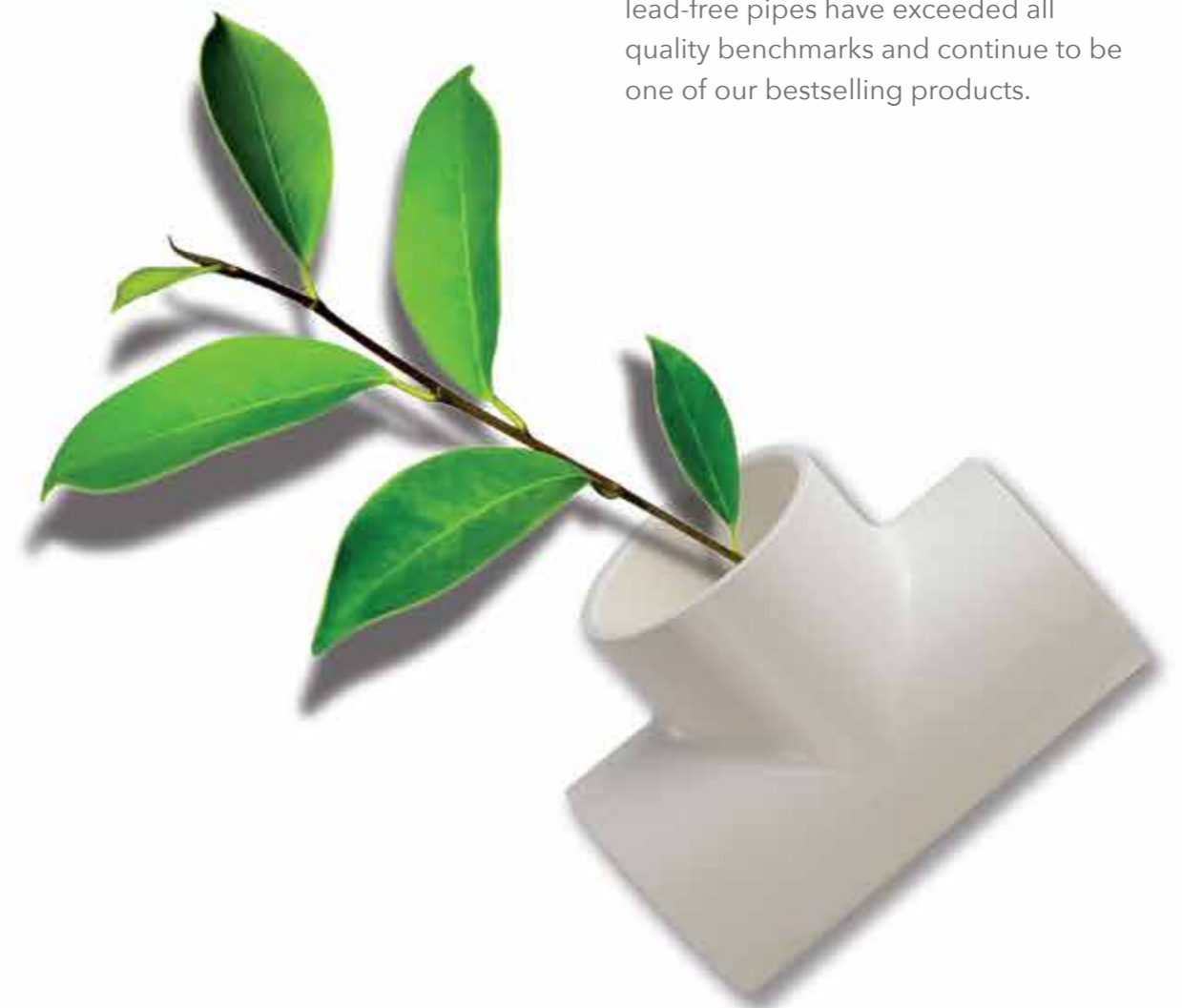



ABOUT **ASTRAL** Aquarius®

ASTRAL Aquarius ASTM uPVC pipes and fittings are lead-free and hence non-toxic, easy to install and are made for life time trouble free service. ASTRAL Aquarius pipes and fittings are available in range of 15 mm (½") to 300 mm (12") with two different classes - SCH 40 and SCH 80. As the full line leading manufacturer of CPVC pipes and fittings for residential and industrial applications and now with ASTM uPVC pressure pipes and fittings, ASTRAL can be your one stop source for all the plastic piping system which you require for a lifetime plumbing solution.

THE DIFFERENCE BETWEEN uPVC & PVC

There has been a lot of confusion in the thermoplastics industry regarding the use of the terms uPVC and PVC when specifying thermoplastic piping products. For many years, certain regions of the world have preferred using the term uPVC when specifying unplasticized Polyvinyl Chloride piping products while other regions of the world, The United State of America for instance, prefer the acronym PVC (less the U) when specifying the same unplasticized PVC piping products. So uPVC and PVC both indicate same material - unplasticized or Rigid PVC. The most important aspect of specifying PVC piping products is not the abbreviation but the cell classification of the thermoplastic material. For rigid, unplasticized Type I Grade I PVC material with a hydrostatic design stress of 2000 psi the cell classification is 12454. These numbers indicate the minimum physical properties that a rigid, unplasticized thermoplastic compound must meet as per ASTM D1784 to be used in the manufacturing of pressure piping components. In summary, whether a thermoplastic vinyl piping, product is specified as uPVC is not important, it is the cell classification, and materials' physical properties that is most important.

PVC - POLYVINYL CHLORIDE

PVC is one of the specified thermoplastic for piping system components, including valves, fittings, flanges and many speciality products. PVC has excellent chemical and corrosion resistance to a broad range of fluids. ASTRAL uPVC materials conform to ASTM Cell Classification 12454-B of ASTM D1784 (formally designated as Type I, Grade I). The maximum recommended service temperature of PVC products is 60°C (140°F).

WHAT MAKES PVC IMPORTANT?

PVC makes a major contribution to the quality, safety and cost-effectiveness of construction materials, as well as helping to reduce the environmental impact of completed projects. PVC is the most widely used polymer in building and construction applications and over 50 percent of Western Europe's annual PVC production is used in this sector. PVC has a versatility that helps to meet modern and future design needs.

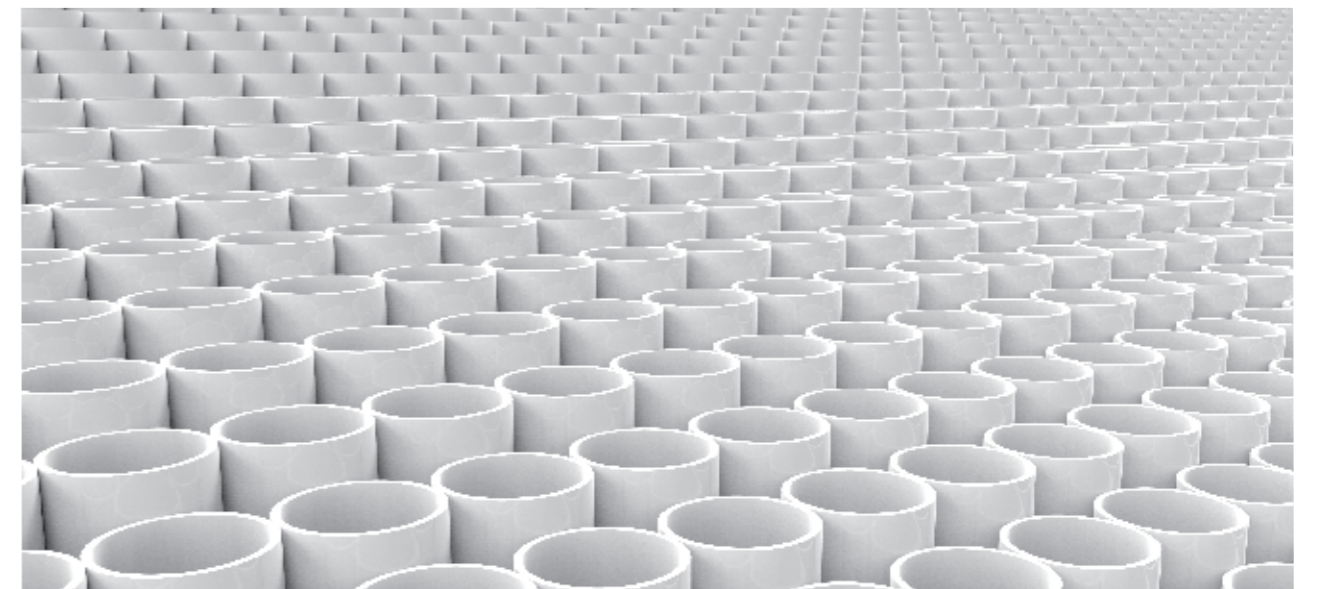

BENEFITS OF ASTRAL AQUARIUS SYSTEM OVER OTHER uPVC SYSTEMS

THREADED uPVC PIPE

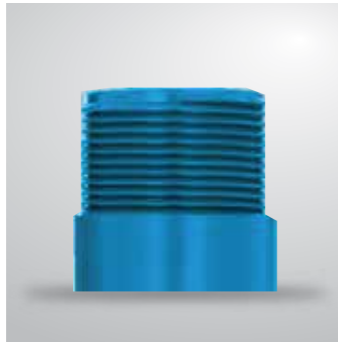

SOLVENT WELD uPVC PIPE



ASTRAL Aquarius uPVC pipes being lead free are non-toxic and hence favoured for use in applications such as potable water pipes. ASTRAL Aquarius uPVC plumbing system utilizes NSF (National Sanitation Foundation) approved one-step solvent cement, specifically formulated for the use. Joining is accomplished quickly and efficiently utilizing inexpensive tools thereby greatly reducing labour and installation cost. ASTRAL Aquarius uPVC pipes & fittings exhibit the well-known physical characteristics and other benefits of conventional uPVC piping such as good chemical and corrosion resistance, low thermal conductivity, high strength-to-weight ratio, good impact resistance and ease of installation.



ASTRAL AQUARIUS UPVC SOLVENT JOINT PLUMBING SYSTEM DOUBLES THE PRESSURE BEARING CAPACITY COMPARED TO THREADED uPVC PIPING SYSTEM.

CERTIFICATES & APPROVALS



STANDARDS & SPECIFICATIONS

- ASTM D 1784 - Rigid Poly Vinyl Chloride (PVC) Compounds
- ASTM D 1785 - Poly Vinyl Chloride (PVC) Plastic Pipes, SCH 40 & SCH 80
- ASTM D 2466 - Socket type Poly Vinyl Chloride (PVC) Plastic Pipe Fittings, SCH 40
- ASTM D 2467 - Socket type Poly Vinyl Chloride (PVC) Plastic Pipe Fittings, SCH 80
- ASTM D 2564 - Solvent Cements for Plastic Pipes & Fittings
- ASTM F 1498 - Taper Pipe threads 60° for Thermoplastics Pipe & Fittings
- ASTM D 2774 - Underground Installation of Thermoplastic Pipes
- ISO 7/1 - Pipe threads where pressure joints are made on threads - Part 1: Designation, Dimension & Tolerances

DESCRIPTIVE CODES

- ASTM** - American Society for Testing of Materials.
- BSP** - British Standard Pipe
- NPT** - National Pipe Threads (ANSI)
- MIPT** - Male Iron Pipe Threads
- SPIGOT** - Spigot End (IPS)
- MBSP** - Male BSP Threads
- PVC** - Poly Vinyl Chloride
- ANSI** - American National Standards Institute
- IPS** - Iron Pipe Size (ASTM)
- FIPT** - Female Iron Pipe Threads
- SOCKET** - Solvent Weld Socket
- FBSP** - Female BSP Threads
- NSF** - National Sanitation Foundation
- EPDM** - Ethylene Propylene Rubber



IMPORTANT FOR INSTALLERS & USERS

WATER HAMMER

ASTRAL recommends that all uPVC plastic piping systems be designed and constructed to avoid excessive WATER HAMMER. Water hammer can cause damage and failure to pipe, valves and fittings within the piping system

THREADED CONNECTIONS

Use a quality grade thread sealant. Do not use substances that could cause stress cracking to plastic. Major attention must be given while making plastic thread joints. 1 to 2 turns beyond FINGER TIGHT is generally all that is required to make a sound plastic connection. Unnecessary OVER TIGHTENING will cause DAMAGE TO BOTH PIPES & FITTINGS. Also give proper attention while selecting the threaded fittings, as ASTRAL manufacture some fittings with NPT threads & some fittings with BSP threads to give more versatility to customer NPT threads which are not compatible with BSP threads.

SEAL & GASKET LUBRICANTS

Some lubricants, including vegetable oils are known to cause stress cracking in thermoplastic materials. A mild soap or commercially available pipe gasket lubricant suitable for uPVC is recommended where lubrication is required for installation or maintenance service (especially with Flange joints). Choice of lubricant is at the discretion of the installer.

FLOW VELOCITIES

System should not be operated or flushed out at flow velocities greater than 5 feet per second.

The following information is provided as a guide only. Actual allowable working pressure may vary widely according to conditions. Additionally, pressure de-rating at elevated temperatures must be taken into account. Certain fitting configurations may have other assigned pressure limitations (i.e., Wyes, Unions, Flanges, Valves etc). Contact Astral Technical Services for additional information.

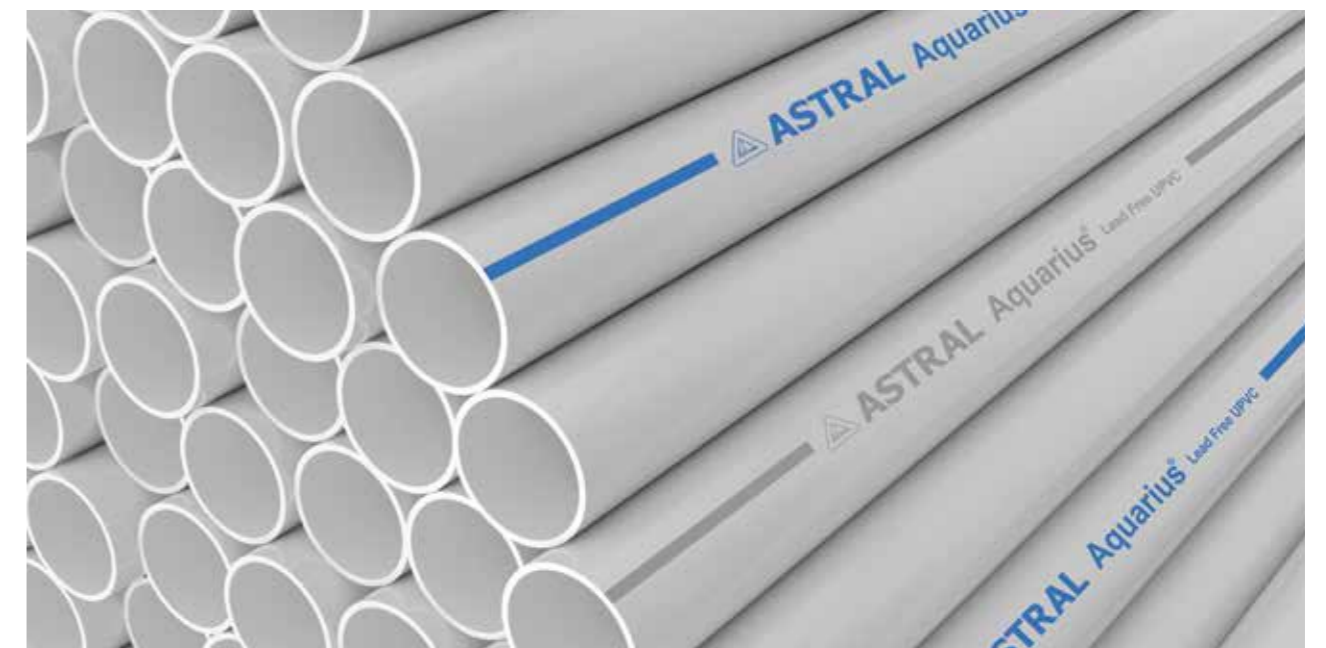

KEY PROPERTIES

STRONG AND LIGHT WEIGHT

ASTRAL Aquarius lead-free plumbing system is tough, durable with high tensile and impact strength. The system is light weight and can be transported easily from one place to another.

DURABLE

ASTRAL Aquarius lead-free plumbing system is durable and free from weaknesses caused by rusting, weathering and chemical action and hence imparts service life of more than 50 years.

MAXIMUM FLOW RATE

Smooth inner surface ensures high flow rate and low frictional losses. The system is leach and scale free.

CHEMICAL RESISTANCE

uPVC is generally inert to most mineral acids, alkalies, salts and paraffinic hydrocarbon solutions. For more information on uPVC chemical resistance refer to Chemical Resistance of Rigid Vinyls Based.

FIRE RESISTANT

ASTRAL Aquarius lead-free plumbing system is inherently difficult to ignite and stops burning once the source of heat is removed. Compared to its common plastic alternatives, uPVC performs better in terms of lower combustibility, flammability, flame propagation and heat release. Newly developed advantages in terms of lower acid emissions, smoke generation and enhanced fire resistance.

UV STABILIZED

ASTRAL Aquarius lead-free plumbing system can be used in sunlight exposed conditions. However, ASTRAL recommends a standard grade of exterior latex paint (water base) which will protect the system adequately.

GOOD INSULATOR

ASTRAL Aquarius pipes are non-conductor of electricity. So it makes the plumbing system safe when working with electrical tools or equipment.

WIDE RANGE

ASTRAL Aquarius lead-free plumbing system is available from 1/2" (15 mm) to 12" (300 mm) with wide range of fittings, transition fittings, valves and specially designed brass inserted fittings to suit any design criteria.

EASY TO INSTALL

ASTRAL Aquarius lead-free pipes can be cut, shaped, welded and joined easily.

SAFE MATERIAL FOR DRINKING WATER

ASTRAL Aquarius pipes are non-toxic and lead-free which makes them a safe material for potable water. It is also the world's most researched and thoroughly tested material for uPVC which meets all international standards for safety and health for both the products and applications.

FIELDS OF APPLICATION

- Cold Water Plumbing Application
- Water Distribution Mains
- Industrial Process Lines
- Swimming Pools
- Plants & Tanning Plants
- Hand Pumps
- Sugar, Paper & Distillery Industries
- Salt Water Line
- Aggressive Corrosive Fluid Transportation
- Coal Washing & Ash Handling
- Down Take Lines

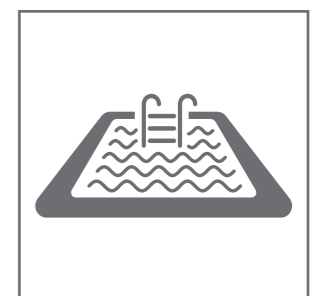

PRESSURE PIPES AND FITTINGS

PRESSURE RATING @23°C uPVC SCHEDULE 40

| Nominal Size | | | Average Outside Diameter | | Minimum Wall Thickness | | Maximum Work Pressure at 73°F (PSI) | Maximum Work Pressure at 23°C (kg/cm ²) |
|--------------|------|-------|--------------------------|--------|------------------------|-------|-------------------------------------|---|
| (cm) | (mm) | (in.) | (in.) | (mm) | (in.) | (mm) | | |
| 1.5 | 15 | ½ | 0.840 | 21.34 | 0.109 | 2.77 | 600 | 42.19 |
| 2.0 | 20 | ¾ | 1.050 | 26.67 | 0.113 | 2.87 | 480 | 33.75 |
| 2.5 | 25 | 1 | 1.315 | 33.40 | 0.133 | 3.38 | 450 | 31.64 |
| 3.2 | 32 | 1¼ | 1.660 | 42.16 | 0.140 | 3.56 | 370 | 26.01 |
| 4.0 | 40 | 1½ | 1.900 | 48.26 | 0.145 | 3.68 | 330 | 23.20 |
| 5.0 | 50 | 2 | 2.375 | 60.32 | 0.154 | 3.91 | 280 | 19.69 |
| 6.5 | 65 | 2½ | 2.875 | 73.02 | 0.203 | 5.16 | 330 | 21.09 |
| 8.0 | 80 | 3 | 3.500 | 88.90 | 0.216 | 5.49 | 260 | 18.28 |
| 10.0 | 100 | 4 | 4.500 | 114.30 | 0.237 | 6.02 | 220 | 15.47 |
| 15.0 | 150 | 6 | 6.625 | 168.28 | 0.280 | 7.11 | 180 | 12.66 |
| 20.0 | 200 | 8 | 8.625 | 219.08 | 0.322 | 8.18 | 160 | 11.25 |
| 25.0 | 250 | 10 | 10.750 | 273.05 | 0.365 | 9.27 | 140 | 9.84 |
| 30.0 | 300 | 12 | 12.750 | 323.85 | 0.406 | 10.31 | 130 | 9.14 |

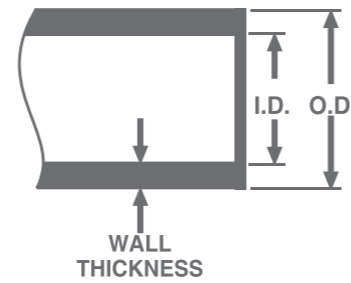

MPa = Mega Pascal 1 MPa = 10 kg / cm² 1 kg / cm² = 14.223343 PSI.

PRESSURE RATING @23°C uPVC SCHEDULE 80

| Nominal Size | | | Average Outside Diameter | | Minimum Wall Thickness | | Maximum Work Pressure at 73°F (PSI) | Maximum Work Pressure at 23°C (kg/cm ²) |
|--------------|------|-------|--------------------------|--------|------------------------|-------|-------------------------------------|---|
| (cm) | (mm) | (in.) | (in.) | (mm) | (in.) | (mm) | | |
| 1.5 | 15 | ½ | 0.840 | 21.34 | 0.147 | 3.73 | 850 | 59.76 |
| 2.0 | 20 | ¾ | 1.050 | 26.67 | 0.154 | 3.91 | 690 | 48.51 |
| 2.5 | 25 | 1 | 1.315 | 33.40 | 0.179 | 4.55 | 630 | 44.29 |
| 3.2 | 32 | 1¼ | 1.660 | 42.16 | 0.191 | 4.85 | 520 | 36.56 |
| 4.0 | 40 | 1½ | 1.900 | 48.26 | 0.200 | 5.08 | 470 | 33.04 |
| 5.0 | 50 | 2 | 2.375 | 60.32 | 0.218 | 5.54 | 400 | 28.12 |
| 6.5 | 65 | 2½ | 2.875 | 73.02 | 0.276 | 7.01 | 420 | 29.53 |
| 8.0 | 80 | 3 | 3.500 | 88.90 | 0.300 | 7.62 | 370 | 26.01 |
| 10.0 | 100 | 4 | 4.500 | 114.30 | 0.337 | 8.56 | 320 | 22.50 |
| 15.0 | 150 | 6 | 6.625 | 168.28 | 0.432 | 10.97 | 280 | 19.69 |
| 20.0 | 200 | 8 | 8.625 | 219.08 | 0.500 | 12.70 | 250 | 17.57 |
| 25.0 | 250 | 10 | 10.750 | 273.05 | 0.593 | 15.06 | 230 | 16.17 |
| 30.0 | 300 | 12 | 12.750 | 323.85 | 0.687 | 17.45 | 230 | 16.17 |

MPa = Mega Pascal 1 MPa = 10 kg / cm² 1 kg / cm² = 14.223343 PSI.

TEMPERATURE PRESSURE DE-RATING FACTOR

The operating pressure of uPVC pipe will be reduced as the operating temperature increases above 23°C (73°F). To calculate this reduction, multiply the operating pressure with the correction factors shown below at a operating temperature of system :

| Operating Temp.°C (°F) | 23 (73) | 27 (80) | 32 (90) | 38 (100) | 43 (110) | 49 (120) | 54 (130) | 60 (140) |
|------------------------|---------|---------|---------|----------|----------|----------|----------|----------|
| uPVC | 100% | 90% | 75% | 62% | 50% | 40% | 30% | 22% |

NOTES : (1) Valves, Unions and Specialty Products have different elevated temperature ratings than pipes. (2) Threaded valves should not be used at temperature above 110°F (43° C) for PVC (3) Flanged joints have a base pressure rating of 150 PSI at 23° C

PVC SCHEDULE 40 AND SCHEDULE 80 FITTINGS

The following information is provided as a guide only. Actual allowable working pressure may vary widely according to conditions. Additionally, pressure de-rating at elevated temperatures must be taken into account. Certain fitting configurations may have other assigned pressure limitations (i.e., Wyes, Unions, Flanges, Valves etc). Contact Astral Technical Services for additional information.

PRESSURE RATING @23°C uPVC SCHEDULE 40

| Nominal Size (in.) | Schedule 40 (kg/cm ²) | | | Schedule 80 (kg/cm ²) | | |
|--------------------|-----------------------------------|------------------------|--------------------------|-----------------------------------|------------------------|--------------------------|
| | Pipe1 | Solvent Cemented Joint | Standard Threaded Joint3 | Pipe1 | Solvent Cemented Joint | Standard Threaded Joint3 |
| ½ | 42.19 | 25.31 | 21.09 | 59.76 | 35.85 | 29.88 |
| ¾ | 33.75 | 20.24 | 16.87 | 48.51 | 29.10 | 24.25 |
| 1 | 31.64 | 18.98 | 15.81 | 44.29 | 26.57 | 22.14 |
| 1¼ | 26.01 | 15.60 | 13.00 | 36.56 | 21.93 | 18.27 |
| 1½ | 23.20 | 13.92 | 11.60 | 33.04 | 19.82 | 16.52 |
| 2 | 19.69 | 11.81 | 9.84 | 28.12 | 16.87 | 14.06 |
| 2½ | 21.09 | 12.65 | 10.54 | 29.53 | 17.71 | 14.76 |
| 3 | 18.28 | 10.96 | 9.13 | 26.01 | 15.60 | 13.00 |
| 4 | 15.47 | 9.28 | 7.73 | 22.50 | 13.49 | 11.24 |
| 6 | 12.66 | 7.59 | 6.32 | 19.69 | 11.81 | 9.84 |
| 8 | 11.25 | 6.74 | 5.62 | 17.57 | 10.54 | 8.78 |
| 10 | 9.84 | 5.90 | 4.92 | 16.17 | 9.70 | 8.08 |
| 12 | 9.14 | 5.48 | 4.56 | 16.17 | 9.70 | 8.08 |

NOTES : (1) Water pressure Ratings At 73°F (23°C) for Schedule 40 and Schedule 80 Plastic Pipe, ASTM D 1785 for PVC.

(2) Threading of Schedule 40 plastic pipe is not permitted. Recommended pressures apply to molded fittings only.

(Not For Use With Compressed Air or Gas)

PHYSICAL PROPERTIES OF PVC MATERIALS

| PROPERTY | UNITS | PVC | ASTM NO. |
|---|----------------------|------------------------|----------|
| Specific Gravity | g/cc | 1.41 - 1.46 | D 792 |
| Tensile Strength (73°F) | PSI | 7,200 | D 638 |
| Modulus of Elasticity in Tension (73°F) | PSI | 4,60,000 | D 638 |
| Flexural Strength (73°F) | PSI | 13,200 | D 790 |
| Izod Impact (notched at 73°F) | ft lb/in. | 0.65 | D 256 |
| Hardness (Durometer D) | ---- | 80 ± 3 | D 2240 |
| Hardness (Rockwell R) | ---- | 110 - 120 | D 785 |
| Compressive Strength (73°F) | PSI | 9,000 | D 695 |
| Hydrostatic Design Stress | PSI | 2,000 | D 1598 |
| Coefficient of Linear Expansion | in./in./°F | 3.1 x 10 ⁻⁵ | D 696 |
| Heat Deflection Temperature at 66 psi | °F | 165 | D 648 |
| Coefficient of Thermal Conductivity | BTU/hr/sq. ft/°F/in. | 1.2 | C 177 |
| Specific Heat | BTU/F/lb | 0.25 | D 2766 |
| Limiting Oxygen Index | % | 43 | D 2863 |
| Water Absorption (24 hrs at 73°F) | % weight gain | 0.05 | D 570 |
| Cell Classification-Pipe | ---- | 12454-B | D 1784 |
| Cell Classification-Fittings | ---- | 12454-B | D 1784 |

Above data is based upon information provided by the raw material manufacturers. It should be used only as a recommendation and not as a guarantee of performance.

BASIC SOCKET DIMENSIONS

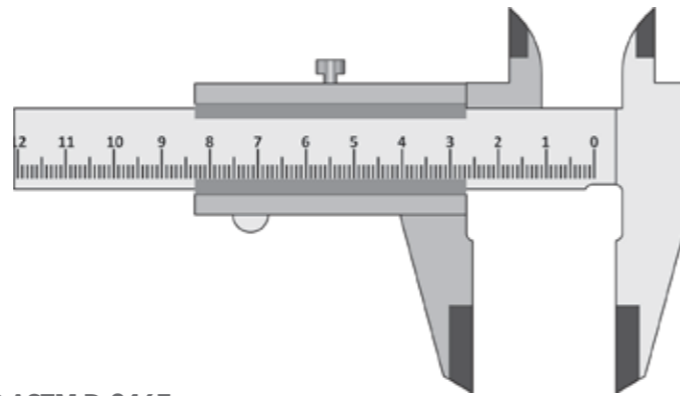

SCHEDULE 40 AS PER ASTM D-2466, SCHEDULE 80 AS PER ASTM D-2467

| Nominal Size | | Diameter (in.) | | | Socket Length Minimum C (in.) | |
|--------------|------|----------------|-------------|-----------|-------------------------------|--------|
| | | Entrance A | Bottom B | Tolerance | SCH 40 | SCH 80 |
| (in.) | (mm) | | | | | |
| 1/2 | 15 | 0.848 | 0.836 | ±0.004 | 0.688 | 0.875 |
| 3/4 | 20 | 1.058 | 1.046 | ±0.004 | 0.719 | 1.000 |
| 1 | 25 | 1.325 | 1.310 | ±0.005 | 0.875 | 1.125 |
| 1 1/4 | 32 | 1.670 | 1.655 | ±0.005 | 0.938 | 1.250 |
| 1 1/2 | 40 | 1.912 | 1.894 | ±0.006 | 1.094 | 1.375 |
| 2 | 50 | 2.387 | 2.369 | ±0.006 | 1.156 | 1.500 |
| 2 1/2 | 65 | 2.889 | 2.868 | ±0.007 | 1.750 | 1.750 |
| 3 | 80 | 3.516 | 3.492 | ±0.008 | 1.875 | 1.875 |
| 4 | 100 | 4.518 | 4.491 | ±0.009 | 2.000 | 2.250 |
| 6 | 150 | 6.647 | 6.614 | ±0.011 | 3.000 | 3.000 |
| 8 | 200 | 8.655 | 8.610 | ±0.015 | 4.000 | 4.000 |
| 10 | 250 | 10.780 | 10.735 | ±0.015 | 5.000 | 5.000 |
| 12 | 300 | 12.780 | 12.735 | ±0.015 | 6.000 | 6.000 |

AMERICAN NATIONAL STANDARD TAPER PIPE THREADS (NPT)
ANSI STANDARD B1.20.1 ASTM STANDARD F 1498

| Nominal Size | | Threads per inch | Effective Thread Length L (in.) | Pitch of Thread P (in.) |
|--------------|------|------------------|---------------------------------|-------------------------|
| (in.) | (mm) | | | |
| 1/2 | 15 | 14 | 0.5337 | 0.07143 |
| 3/4 | 20 | 14 | 0.5457 | 0.07143 |
| 1 | 25 | 11 1/2 | 0.6828 | 0.08696 |
| 1 1/4 | 32 | 11 1/2 | 0.7068 | 0.08696 |
| 1 1/2 | 40 | 11 1/2 | 0.7235 | 0.08696 |
| 2 | 50 | 11 1/2 | 0.7565 | 0.08696 |
| 2 1/2 | 65 | 8 | 1.1375 | 0.12500 |
| 3 | 80 | 8 | 1.2000 | 0.12500 |
| 4 | 100 | 8 | 1.3000 | 0.12500 |

BSP ISO 7/1 PARELLEL THREADS

| Nominal Size | | Threads per inch | Effective Thread Length L (in.) | Pitch of Thread P (in.) |
|--------------|------|------------------|---------------------------------|-------------------------|
| (in.) | (mm) | | | |
| 1/2 | 15 | 14 | 13.152 | 1.8143 |
| 3/4 | 20 | 14 | 14.514 | 1.8143 |
| 1 | 25 | 11 | 16.714 | 2.3091 |
| 1 1/4 | 32 | 11 | 19.050 | 2.3091 |
| 1 1/2 | 40 | 11 | 19.050 | 2.3091 |
| 2 | 50 | 11 | 23.378 | 2.3091 |
| 2 1/2 | 65 | 11 | 26.698 | 2.3091 |
| 3 | 80 | 11 | 29.873 | 2.3091 |
| 4 | 100 | 11 | 35.791 | 2.3091 |

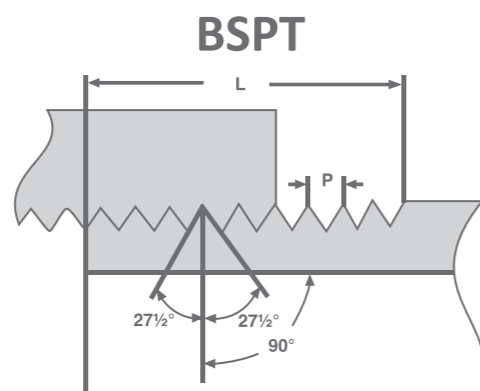
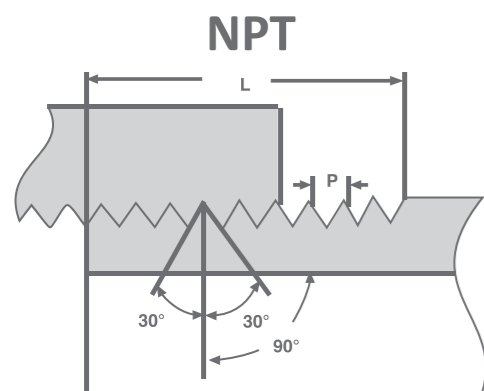

PRODUCT



RANGE

uPVC PRESSURE PIPES

AS PER ASTM D-1785



PIPE SCHEDULE - 40 (3 MTR. LENGTH)

| Size (cm) | Size (inch) | Product Code | Std. Pkg. (Nos.) |
|-----------|-------------|--------------|------------------|
| 1.5 | ½ | M051400301 | 50 |
| 2.0 | ¾ | M051400302 | 30 |
| 2.5 | 1 | M051400303 | 20 |
| 3.2 | 1¼ | M051400304 | 15 |
| 4.0 | 1½ | M051400305 | 10 |
| 5.0 | 2 | M051400306 | 08 |
| 6.5 | 2½ | M051400307 | 05 |
| 8.0 | 3 | M051400308 | 03 |
| 10.0 | 4 | M051400309 | 02 |
| 15.0 | 6 | M051400310 | 01 |
| 20.0 | 8 | M051400311 | 01 |
| 25.0 | 10 | M051400312 | 01 |
| 30.0 | 12 | M051400313 | 01 |



PIPE SCHEDULE - 40 (6 MTR. LENGTH)

| Size (cm) | Size (inch) | Product Code | Std. Pkg. (Nos.) |
|-----------|-------------|--------------|------------------|
| 1.5 | ½ | M051400601 | 30 |
| 2.0 | ¾ | M051400602 | 20 |
| 2.5 | 1 | M051400603 | 15 |
| 3.2 | 1¼ | M051400604 | 10 |
| 4.0 | 1½ | M051400605 | 10 |
| 5.0 | 2 | M051400606 | 06 |
| 6.5 | 2½ | M051400607 | 05 |
| 8.0 | 3 | M051400608 | 03 |
| 10.0 | 4 | M051400609 | 02 |
| 15.0 | 6 | M051400610 | 01 |
| 20.0 | 8 | M051400611 | 01 |
| 25.0 | 10 | M051400612 | 01 |
| 30.0 | 12 | M051400613 | 01 |

uPVC PRESSURE FITTINGS

SCHEDULE 40 AS PER ASTM D2466



COUPLER - SOC



| Size (cm) | Size (inch) | Product Code | Std. Pkg. (Nos.) |
|-----------|-------------|--------------|------------------|
| 1.5 | ½ | M052401001 | 1400 |
| 2.0 | ¾ | M052401002 | 300 |
| 2.5 | 1 | M052401003 | 350 |
| 3.2 | 1¼ | M052401004 | 200 |
| 4.0 | 1½ | M052401005 | 150 |
| 5.0 | 2 | M052401006 | 110 |
| 6.5 | 2½ | M052401007 | 50 |
| 8.0 | 3 | M052401008 | 35 |
| 10.0 | 4 | M052401009 | 24 |
| 15.0 | 6 | M052401010 | 02 |



ELBOW 90° - SOC



| Size (cm) | Size (inch) | Product Code | Std. Pkg. (Nos.) |
|-----------|-------------|--------------|------------------|
| 1.5 | ½ | M052400501 | 1000 |
| 2.0 | ¾ | M052400502 | 500 |
| 2.5 | 1 | M052400503 | 250 |
| 3.2 | 1¼ | M052400504 | 150 |
| 4.0 | 1½ | M052400505 | 110 |
| 5.0 | 2 | M052400506 | 65 |
| 6.5 | 2½ | M052400507 | 35 |
| 8.0 | 3 | M052400508 | 25 |
| 10.0 | 4 | M052400509 | 14 |
| 15.0 | 6 | M052400510 | 03 |

SOC - SOCKET

SOC - SOCKET # Shortly Introducing
*Trading items are in grey colour.

uPVC PRESSURE FITTINGS

SCHEDULE 40 AS PER ASTM D-2466



ELBOW 90° (SOC X THREAD)



| Size (cm) | Size (inch) | Product Code | Std. Pkg. (Nos.) |
|-----------|-------------|--------------|------------------|
| 1.5 | ½ | M052400801 | 450 |
| 2.0 | ¾ | M052400802 | 250 |
| 2.5 | 1 | M052400803 | 125 |
| 3.2 | 1¼ | M052400804 | 50 |
| 4.0 | 1½ | M052400805 | 60 |
| 5.0 | 2 | M052400806 | 30 |



ELBOW 45° - SOC



| Size (cm) | Size (inch) | Product Code | Std. Pkg. (Nos.) |
|-----------|-------------|--------------|------------------|
| 1.5 | ½ | M052402301 | 500 |
| 2.0 | ¾ | M052402302 | 300 |
| 2.5 | 1 | M052402303 | 325 |
| 3.2 | 1¼ | M052402304 | 100 |
| 4.0 | 1½ | M052402305 | 75 |
| 5.0 | 2 | M052402306 | 40 |

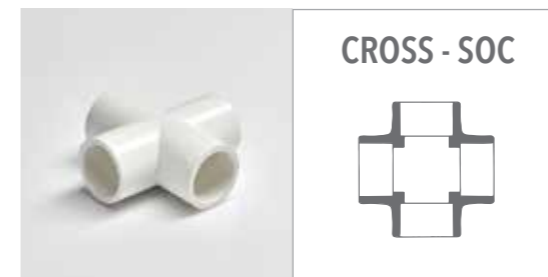

CROSS - SOC

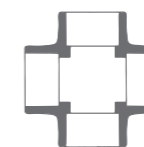

| Size (cm) | Size (inch) | Product Code | Std. Pkg. (Nos.) |
|-----------|-------------|--------------|------------------|
| 1.5 | ½ | M052402401 | 200 |
| 2.0 | ¾ | M052402402 | 100 |
| 2.5 | 1 | 420-010** | 10 |
| 3.2 | 1¼ | 420-012* | 10 |
| 4.0 | 1½ | 420-015* | 10 |
| 5.0 | 2 | 420-020* | 10 |



TEE - SOC



| Size (cm) | Size (inch) | Product Code | Std. Pkg. (Nos.) |
|-----------|-------------|--------------|------------------|
| 1.5 | ½ | M052400101 | 550 |
| 2.0 | ¾ | M052400102 | 300 |
| 2.5 | 1 | M052400103 | 175 |
| 3.2 | 1¼ | M052400104 | 100 |
| 4.0 | 1½ | M052400105 | 70 |
| 5.0 | 2 | M052400106 | 40 |
| 6.5 | 2½ | M052400107 | 27 |
| 8.0 | 3 | M052400108 | 18 |
| 10.0 | 4 | M052400109 | 10 |
| 15.0 | 6 | M052400110 | 02 |



TEE - THREAD

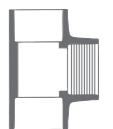

| Size (cm) | Size (inch) | Product Code | Std. Pkg. (Nos.) |
|-----------|-------------|--------------|------------------|
| 1.5 | ½ | M052400401 | 300 |
| 2.0 | ¾ | M052400402 | 150 |
| 2.5 | 1 | M052400403 | 75 |
| 3.2 | 1¼ | M052400404 | 50 |
| 4.0 | 1½ | M052400405 | 40 |
| 5.0 | 2 | M052400406 | 20 |



REDUCER ELBOW 90° (SOC)

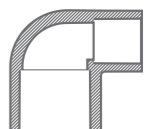

| Size (cm) | Size (inch) | Product Code | Std. Pkg. (Nos.) |
|-----------|-------------|--------------|------------------|
| 2.0 x 1.5 | ¾ x ½ | M052800614 | 250 |
| 2.5 x 1.5 | 1 x ½ | M052800615 | 150 |
| 2.5 x 2.0 | 1 x ¾ | M052800616 | 150 |

uPVC PRESSURE FITTINGS

SCHEDULE 40 AS PER ASTM D-2466

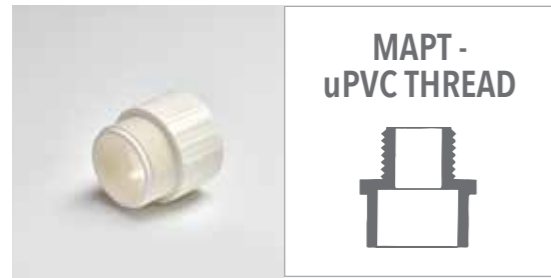

| Size (cm) | Size (inch) | Product Code | Std. Pkg. (Nos.) |
|-----------|-------------|--------------|------------------|
| 1.5 | ½ | M052401301 | 1700 |
| 2.0 | ¾ | M052401302 | 500 |
| 2.5 | 1 | M052401303 | 500 |
| 3.2 | 1¼ | M052401304 | 480 |
| 4.0 | 1½ | M052401305 | 320 |
| 5.0 | 2 | M052401306 | 192 |



| Size (cm) | Size (inch) | Product Code | Std. Pkg. (Nos.) |
|-----------|-------------|--------------|------------------|
| 1.5 | ½ | M052401601 | 1300 |
| 2.0 | ¾ | M052401602 | 400 |
| 2.5 | 1 | M052401603 | 400 |
| 3.2 | 1¼ | M052401604 | 130 |
| 4.0 | 1½ | M052401605 | 100 |
| 5.0 | 2 | M052401606 | 70 |
| 2.0x1.5 | ¾x½ | M052401614 | 700 |

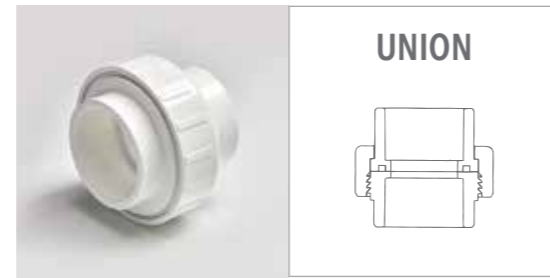

| Size (cm) | Size (inch) | Product Code | Std. Pkg. (Nos.) |
|-----------|-------------|--------------|------------------|
| 1.5 | ½ | M052802601 | 200 |
| 2.0 | ¾ | M052802602 | 120 |
| 2.5 | 1 | M052802603 | 80 |
| 3.2 | 1¼ | M052802604 | 50 |
| 4.0 | 1½ | M052802605 | 80 |
| 5.0 | 2 | M052802606 | 30 |
| 6.5 | 2½ | M052802607 | 15 |
| 8.0 | 3 | M052802608 | 10 |
| 10.0 | 4 | M052802609 | 04 |
| 15.0 | 6 | 897-060* | As Req. |

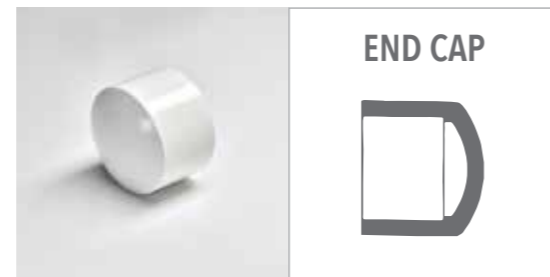

| Size (cm) | Size (inch) | Product Code | Std. Pkg. (Nos.) |
|-----------|-------------|--------------|------------------|
| 1.5 | ½ | M052404101 | 1200 |
| 2.0 | ¾ | M052404102 | 600 |
| 2.5 | 1 | M052404103 | 350 |
| 3.2 | 1¼ | M052404104 | 220 |
| 4.0 | 1½ | M052404105 | 270 |
| 5.0 | 2 | M052404106 | 90 |
| 6.5 | 2½ | M052404107 | 50 |
| 8.0 | 3 | M052404108 | 35 |
| 10.0 | 4 | M052404109 | 22 |



| Size (cm) | Size (inch) | Product Code | Std. Pkg. (Nos.) |
|-----------|-------------|--------------|------------------|
| 1.5 | ½ | M052402501 | 80 |
| 2.0 | ¾ | M052402502 | 60 |
| 2.5 | 1 | M052402503 | 40 |
| 3.2 | 1¼ | M052402504 | 30 |
| 4.0 | 1½ | M052402505 | 20 |
| 5.0 | 2 | M052402506 | 15 |



| Size (cm) | Size (inch) | Product Code | Std. Pkg. (Nos.) |
|-----------|-------------|--------------|------------------|
| 1.5 | ½ | M052806501 | 200 |
| 2.0 | ¾ | M052806502 | 140 |
| 2.5 | 1 | M052806503 | 80 |
| 3.2 | 1¼ | M052806504 | 40 |
| 4.0 | 1½ | M052806505 | 30 |
| 5.0 | 2 | M052806506 | 20 |



| Size (cm) | Size (inch) | Product Code | Std. Pkg. (Nos.) |
|-----------|-------------|--------------|------------------|
| 2.0 | ¾ | M0528010202 | 75 |
| 2.5 | 1 | M0528010203 | 60 |
| 3.2 | 1¼ | M0528010204 | 70 |
| 4.0 | 1½ | M0528010205 | 60 |
| 5.0 | 2 | M0528010206 | 35 |



| Size (cm) | Size (inch) | Product Code | Std. Pkg. (Nos.) |
|-----------|-------------|--------------|------------------|
| 1.5 | ½ | F052806501 | 80 |
| 2.0 | ¾ | F052806502 | 60 |
| 2.5 | 1 | F052806503 | 40 |
| 3.2 | 1¼ | F052806504 | 18 |
| 4.0 | 1½ | F052806505 | 12 |
| 5.0 | 2 | F052806506 | 08 |
| 6.5 | 2½ | F052806507* | 15 |
| 8.0 | 3 | F052806508* | 09 |



| Size (cm) | Size (inch) | Product Code | Std. Pkg. (Nos.) |
|-----------|-------------|--------------|------------------|
| 2.0 x 1.5 | ¾ x ½ | M052400214 | 350 |
| 2.5 x 1.5 | 1 x ½ | M052400215 | 200 |
| 2.5 x 2.0 | 1 x ¾ | M052400216 | 175 |
| 3.2 x 1.5 | 1¼ x ½ | M052400217 | 120 |
| 3.2 x 2.0 | 1¼ x ¾ | M052400218 | 120 |
| 3.2 x 2.5 | 1¼ x 1 | M052400219 | 120 |
| 4.0 x 1.5 | 1½ x ½ | M052400220 | 90 |
| 4.0 x 2.0 | 1½ x ¾ | M052400221 | 40 |
| 4.0 x 2.5 | 1½ x 1 | M052400222 | 80 |
| 4.0 x 3.2 | 1½ x 1¼ | M052400223 | 70 |
| 5.0 x 1.5 | 2 x ½ | M052400224 | 60 |
| 5.0 x 2.0 | 2 x ¾ | M052400225 | 60 |
| 5.0 x 2.5 | 2 x 1 | M052400226 | 60 |
| 5.0 x 3.2 | 2 x 1¼ | M052400227 | 50 |
| 5.0 x 4.0 | 2 x 1½ | M052400228 | 50 |

SOC - SOCKET, THD-THREADED

All the items where product code starts with "F" are fabricated items.
SOC - SOCKET, SPG-SPIGOT, THD-THREADED # Shortly Introducing

uPVC PRESSURE FITTINGS

SCHEDULE 40 AS PER ASTM D-2466

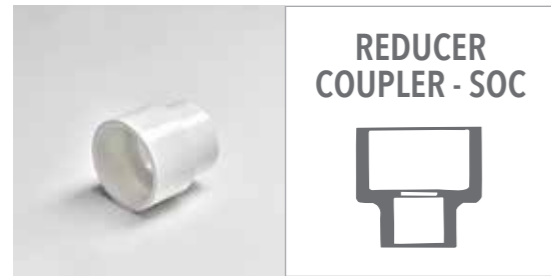

| Size (cm) | Size (inch) | Product Code | Std. Pkg. (Nos.) |
|-----------|-------------|--------------|------------------|
| 2.0 x 1.5 | ¾ x ½ | M052401114 | 400 |
| 2.5 x 1.5 | 1 x ½ | M052401115 | 550 |
| 2.5 x 2.0 | 1 x ¾ | M052401116 | 200 |
| 3.2 x 2.0 | 1¼ x ¾ | A052401118 | As Req. |
| 3.2 x 2.5 | 1¼ x 1 | M052401119 | 175 |
| 4.0 x 2.5 | 1½ x 1 | M052401122 | 150 |
| 4.0 x 3.2 | 1½ x 1¼ | M052401123 | 150 |
| 5.0 x 2.5 | 2 x 1 | M052401126 | 120 |
| 5.0 x 3.2 | 2 x 1¼ | M052401127 | 40 |
| 5.0 x 4.0 | 2 x 1½ | M052401128 | 50 |



| Size (cm) | Size (inch) | Product Code | Std. Pkg. (Nos.) |
|-----------|-------------|--------------|------------------|
| 2.0 x 1.5 | ¾ x ½ | M052801414 | 150 |
| 2.5 x 1.5 | 1 x ½ | M052801415 | 100 |
| 2.5 x 2.0 | 1 x ¾ | M052801416 | 100 |



| Size (cm) | Size (inch) | Product Code | Std. Pkg. (Nos.) |
|-----------|-------------|--------------|------------------|
| 2.0 x 1.5 | ¾ x ½ | M052801714 | 100 |
| 2.5 x 1.5 | 1 x ½ | M052801215 | 100 |
| 2.5 x 2.0 | 1 x ¾ | M052801216 | 75 |



| Size (cm) | Size (inch) | Product Code | Std. Pkg. (Nos.) |
|------------|-------------|--------------|------------------|
| 2.0 x 1.5 | ¾ x ½ | M052401914 | 900 |
| 2.5 x 1.5 | 1 x ½ | M052401915 | 450 |
| 2.5 x 2.0 | 1 x ¾ | M052401916 | 450 |
| 3.2 x 1.5 | 1¼ x ½ | M052401917 | 300 |
| 3.2 x 2.0 | 1¼ x ¾ | M052401918 | 300 |
| 3.2 x 2.5 | 1¼ x 1 | M052401919 | 500 |
| 4.0 x 1.5 | 1½ x ½ | M052401920 | 350 |
| 4.0 x 2.0 | 1½ x ¾ | M052401921 | 200 |
| 4.0 x 2.5 | 1½ x 1 | M052401922 | 350 |
| 4.0 x 3.2 | 1½ x 1¼ | M052401923 | 400 |
| 5.0 x 1.5 | 2 x ½ | M052401924 | 120 |
| 5.0 x 2.0 | 2 x ¾ | M052401925 | 120 |
| 5.0 x 2.5 | 2 x 1 | M052401926 | 100 |
| 5.0 x 3.2 | 2 x 1¼ | M052401927 | 120 |
| 5.0 x 4.0 | 2 x 1½ | M052401928 | 120 |
| 6.5 x 3.2 | 2½ x 1¼ | M052401932 | 25 |
| 6.5 x 4.0 | 2½ x 1½ | M052401933 | 50 |
| 6.5 x 5.0 | 2½ x 2 | M052401934 | 60 |
| 8.0 x 4.0 | 3 x 1½ | M052401939 | 35 |
| 8.0 x 5.0 | 3 x 2 | M052401940 | 35 |
| 8.0 x 6.5 | 3 x 2½ | M052401941 | 35 |
| 10.0 x 5.0 | 4 x 2 | M052401947 | 20 |
| 10.0 x 6.5 | 4 x 2½ | M052401948 | 10 |
| 10.0 x 8.0 | 4 x 3 | M052401949 | 20 |



| Size (cm) | Size (inch) | Product Code | Std. Pkg. (Nos.) |
|-----------|-------------|--------------|------------------|
| 2.5 x 1.5 | 1 x ½ | M052802015 | 250 |



| Size (cm) | Size (inch) | Product Code | Std. Pkg. (Nos.) |
|-----------|-------------|--------------|------------------|
| 1.5 x 1.5 | ½ x ½ | M052800701 | 100 |
| 2.0 x 1.5 | ¾ x ½ | M052800714 | 100 |
| 2.0 x 2.0 | ¾ x ¾ | M052800702 | 75 |
| 2.5 x 1.5 | 1 x ½ | M052800715 | 50 |
| 2.5 x 2.0 | 1 x ¾ | M052800716* | 50 |
| 2.5 x 2.5 | 1 x 1 | M052800703 | 50 |



| Size (cm) | Size (inch) | Product Code | Std. Pkg. (Nos.) |
|-----------|-------------|--------------|------------------|
| 1.5 x 1.5 | ½ x ½ | M052800301 | 100 |
| 2.0 x 1.5 | ¾ x ½ | M052800314 | 50 |
| 2.0 x 2.0 | ¾ x ¾ | M052800302 | 50 |
| 2.5 x 1.5 | 1 x ½ | M052800315 | 25 |
| 2.5 x 2.0 | 1 x ¾ | M052800316 | 25 |
| 2.5 x 2.5 | 1 x 1 | M052800303 | 30 |
| 3.2 x 1.5 | 1¼ x ½ | M052800317 | 20 |

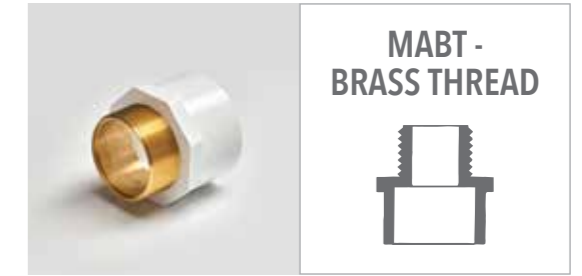

| Size (cm) | Size (inch) | Product Code | Std. Pkg. (Nos.) |
|-----------|-------------|--------------|------------------|
| 1.5 | ½ | M052801401 | 150 |
| 2.0 | ¾ | M052801402 | 100 |
| 2.5 | 1 | M052801403 | 60 |
| 3.2 | 1¼ | M052801404 | 50 |
| 4.0 | 1½ | M052801405 | 40 |
| 5.0 | 2 | M052801406 | 20 |
| 6.5 | 2½ | M052801407 | 09 |
| 8.0 | 3 | M052801408 | 08 |

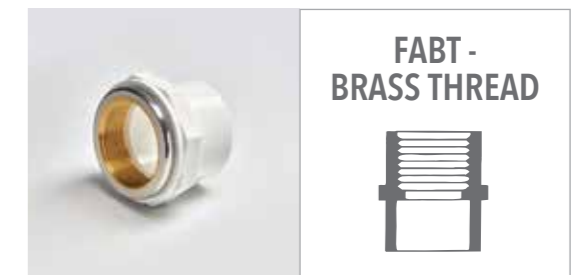

| Size (cm) | Size (inch) | Product Code | Std. Pkg. (Nos.) |
|-----------|-------------|--------------|------------------|
| 1.5 | ½ | M052801701 | 100 |
| 2.0 | ¾ | M052801702 | 100 |
| 2.5 | 1 | M052801703 | 50 |
| 3.2 | 1¼ | M052801704 | 40 |
| 4.0 | 1½ | M052801705 | 30 |
| 5.0 | 2 | M052801706 | 15 |
| 6.5 | 2½ | M052801707 | 09 |
| 8.0 | 3 | M052801708 | 07 |
| 10.0 | 4 | M052801709* | As Req. |

All the items where product code starts with "A" are assembled items.
SOC - SOCKET, SPG-SPIGOT

All the items where product code starts with "F" are fabricated items.
SOC - SOCKET # Shortly Introducing

uPVC PRESSURE FITTINGS

SCHEDULE 40 AS PER ASTM D-2466



| Size (cm) | Size (inch) | Product Code | Std. Pkg. (Nos.) |
|-----------|-------------|--------------|------------------|
| 1.5 | ½ | M052402701 | 80 |
| 2.0 | ¾ | M052402702 | 100 |
| 2.5 | 1 | M052402703 | 70 |
| 3.2 | 1¼ | M052402704 | 40 |
| 4.0 | 1½ | M052402705 | 30 |
| 5.0 | 2 | M052402706 | 15 |

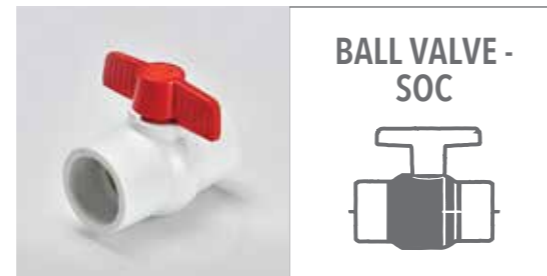

| Size (cm) | Size (inch) | Product Code | Std. Pkg. (Nos.) |
|-----------|-------------|--------------|------------------|
| 1.5 | ½ | 910-041* | 100 |
| 2.0 | ¾ | 910-061* | 100 |
| 2.5 | 1 | 910-081* | 100 |
| 3.2 | 1¼ | 910-101* | 100 |
| 4.0 | 1½ | 910-121* | 48 |
| 5.0 | 2 | 910-161* | 24 |
| 6.5 | 2½ | 910-171* | 12 |
| 8.0 | 3 | 910-181* | 12 |
| 10.0 | 4 | 910-201* | 06 |



| Size (cm) | Size (inch) | Product Code | Std. Pkg. (Nos.) |
|-----------|-------------|--------------|------------------|
| 1.5 | ½ | F052400901# | 120 |
| 2.0 | ¾ | F052400902 | 85 |
| 2.5 | 1 | F052400903 | 50 |
| 3.2 | 1¼ | F052400904 | 30 |
| 4.0 | 1½ | F052400905 | 18 |
| 5.0 | 2 | F052400906 | 12 |
| 6.5 | 2½ | F052400907 | 06 |
| 8.0 | 3 | F052400908 | 05 |
| 10.0 | 4 | F052400909# | As Req. |
| 15.0 | 6 | F052400910# | As Req. |



| Size (cm) | Size (inch) | Product Code | Std. Pkg. (Nos.) |
|-----------|-------------|--------------|------------------|
| 2.5 | ½ x 1 | T143-010M | As Req. |
| 4.0 | ½ x 1½ | T143-015M | As Req. |
| 5.0 | ½ x 2 | T143-020M | As Req. |
| 6.5 | ½ x 2½ | T143-025M | As Req. |
| 8.0 | ½ x 3 | T143-030M | As Req. |
| 10.0 | ½ x 4 | T143-040M | As Req. |
| 12.5 | ½ x 5 | T143-050M | As Req. |
| 15.0 | ½ x 6 | T143-060M | As Req. |
| 2.5 | ½ x 1 | T143-010H | As Req. |
| 4.0 | ½ x 1½ | T143-015H | As Req. |
| 5.0 | ½ x 2 | T143-020H | As Req. |
| 6.5 | ½ x 2½ | T143-025H | As Req. |
| 8.0 | ½ x 3 | T143-030H | As Req. |
| 10.0 | ½ x 4 | T143-040H | As Req. |
| 12.5 | ½ x 5 | T143-050H | As Req. |
| 15.0 | ½ x 6 | T143-060H | As Req. |



| Size (cm) | Size (inch) | Product Code | Std. Pkg. (Nos.) |
|-----------|-------------|--------------|------------------|
| 1.5 | ½ | PVC9120M* | 800 |
| 2.0 | ¾ | PVC9340M* | 500 |
| 2.5 | 1 | PVC9100M* | 400 |
| 3.2 | 1¼ | PVC9105M* | 300 |
| 4.0 | 1½ | PVC9106M* | 250 |
| 5.0 | 2 | PVC9200M* | 200 |



| Size (cm) | Size (inch) | Product Code | Std. Pkg. (Nos.) |
|-----------|-------------|--------------|------------------|
| 1.5 | ½ | 2622-005* | 25 |
| 2.0 | ¾ | 2622-007* | 25 |
| 2.5 | 1 | 2622-010* | 10 |
| 3.2 | 1¼ | 2622-012* | 10 |
| 4.0 | 1½ | 2622-015* | 10 |
| 5.0 | 2 | 2622-020* | 10 |
| 6.5 | 2½ | 2622-025* | 05 |
| 8.0 | 3 | 2622-030* | 03 |
| 10.0 | 4 | 2622-040* | 01 |
| 15.0 | 6 | 2622-060* | 01 |



| Size (cm) | Size (inch) | Product Code | Std. Pkg. (Nos.) |
|-----------|-------------|--------------|------------------|
| 1.5 | ½ | F052402801 | 90 |
| 2.0 | ¾ | F052402802 | 60 |
| 2.5 | 1 | F052402803 | 30 |
| 3.2 | 1¼ | F052402804 | 25 |
| 4.0 | 1½ | F052402805 | 20 |
| 5.0 | 2 | F052402806 | 10 |

Note: Ball Valves rated working pressure is 150 psi (10 kgf/cm²) at 23°C
SOC - SOCKET * Trading items

uPVC PRESSURE PIPES

SCHEDULE 80 AS PER ASTM D1785

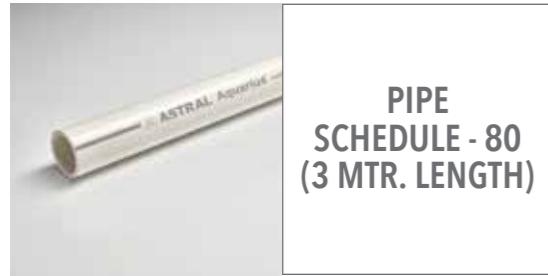

**PIPE
SCHEDULE - 80
(3 MTR. LENGTH)**

| Size (cm) | Size (inch) | Product Code | Std. Pkg. (Nos.) |
|-----------|-------------|--------------|------------------|
| 1.5 | ½ | M051800301 | 50 |
| 2.0 | ¾ | M051800302 | 30 |
| 2.5 | 1 | M051800303 | 20 |
| 3.2 | 1¼ | M051800304 | 15 |
| 4.0 | 1½ | M051800305 | 10 |
| 5.0 | 2 | M051800306 | 08 |
| 6.5 | 2½ | M051800307 | 05 |
| 8.0 | 3 | M051800308 | 03 |
| 10.0 | 4 | M051800309 | 02 |
| 15.0 | 6 | M051800310 | 01 |
| 20.0 | 8 | M051800311 | 01 |
| 25.0 | 10 | M051800312 | 01 |
| 30.0 | 12 | M051800313 | 01 |

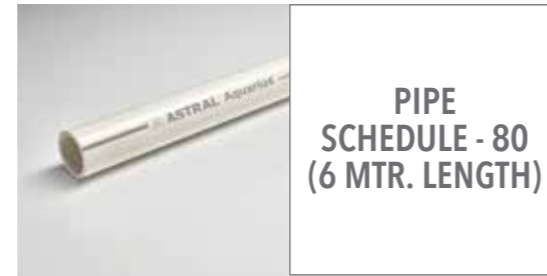

**PIPE
SCHEDULE - 80
(6 MTR. LENGTH)**

| Size (cm) | Size (inch) | Product Code | Std. Pkg. (Nos.) |
|-----------|-------------|--------------|------------------|
| 1.5 | ½ | M051800601 | 30 |
| 2.0 | ¾ | M051800602 | 20 |
| 2.5 | 1 | M051800603 | 15 |
| 3.2 | 1¼ | M051800604 | 10 |
| 4.0 | 1½ | M051800605 | 10 |
| 5.0 | 2 | M051800606 | 06 |
| 6.5 | 2½ | M051800607 | 05 |
| 8.0 | 3 | M051800608 | 03 |
| 10.0 | 4 | M051800609 | 02 |
| 15.0 | 6 | M051800610 | 01 |
| 20.0 | 8 | M051800611 | 01 |
| 25.0 | 10 | M051800612 | 01 |
| 30.0 | 12 | M051800613 | 01 |

uPVC PRESSURE FITTINGS

SCHEDULE 80 AS PER ASTM D2467

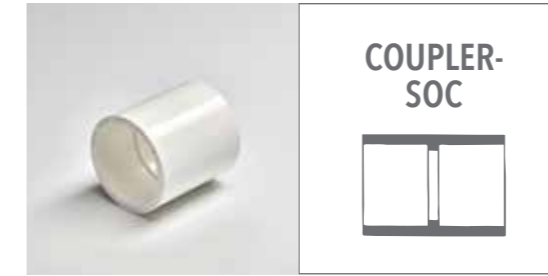

**COUPLER-
SOC**

| Size (cm) | Size (inch) | Product Code | Std. Pkg. (Nos.) |
|-----------|-------------|--------------|------------------|
| 1.5 | ½ | M052801001 | 400 |
| 2.0 | ¾ | M052801002 | 300 |
| 2.5 | 1 | M052801003 | 150 |
| 3.2 | 1¼ | M052801004 | 80 |
| 4.0 | 1½ | M052801005 | 70 |
| 5.0 | 2 | M052801006 | 50 |
| 6.5 | 2½ | M052801007 | 20 |
| 8.0 | 3 | M052801008 | 15 |
| 10.0 | 4 | M052801009 | 12 |
| 15.0 | 6 | M052801010 | 02 |
| 20.0 | 8 | M052801011 | 01 |
| 25.0 | 10 | M052801012 | 01 |
| 30.0 | 12 | M052801013 | 01 |

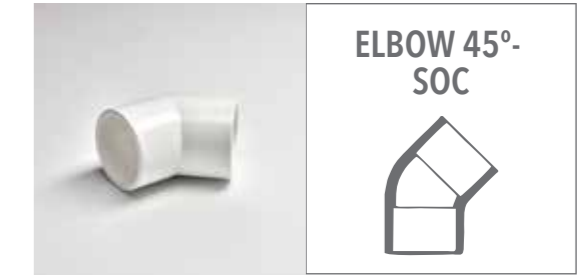

**ELBOW 45°-
SOC**

| Size (cm) | Size (inch) | Product Code | Std. Pkg. (Nos.) |
|-----------|-------------|--------------|------------------|
| 1.5 | ½ | M052802301 | 400 |
| 2.0 | ¾ | M052802302 | 200 |
| 2.5 | 1 | M052802303 | 150 |
| 3.2 | 1¼ | M052802304 | 80 |
| 4.0 | 1½ | M052802305 | 60 |
| 5.0 | 2 | M052802306 | 30 |
| 6.5 | 2½ | M052802307 | 20 |
| 8.0 | 3 | M052802308 | 12 |
| 10.0 | 4 | M052802309 | 06 |
| 15.0 | 6 | M052802310 | 02 |
| 20.0 | 8 | 817-080* | As Req. |
| 25.0 | 10 | 817-100* | As Req. |
| 30.0 | 12 | 817-120* | As Req. |



ELBOW 90° - SOC

| Size (cm) | Size (inch) | Product Code | Std. Pkg. (Nos.) |
|-----------|-------------|--------------|------------------|
| 1.5 | ½ | M052800501 | 300 |
| 2.0 | ¾ | M052800502 | 200 |
| 2.5 | 1 | M052800503 | 125 |
| 3.2 | 1¼ | M052800504 | 60 |
| 4.0 | 1½ | M052800505 | 50 |
| 5.0 | 2 | M052800506 | 25 |
| 6.5 | 2½ | M052800507 | 15 |
| 8.0 | 3 | M052800508 | 10 |
| 10.0 | 4 | M052800509 | 05 |
| 15.0 | 6 | M052800510 | 02 |
| 20.0 | 8 | M052800511 | 01 |
| 25.0 | 10 | 806-100* | As Req. |
| 30.0 | 12 | 806-120* | As Req. |



TEE - SOC

| Size (cm) | Size (inch) | Product Code | Std. Pkg. (Nos.) |
|-----------|-------------|--------------|------------------|
| 1.5 | ½ | M052800101 | 200 |
| 2.0 | ¾ | M052800102 | 125 |
| 2.5 | 1 | M052800103 | 70 |
| 3.2 | 1¼ | M052800104 | 40 |
| 4.0 | 1½ | M052800105 | 30 |
| 5.0 | 2 | M052800106 | 15 |
| 6.5 | 2½ | M052800107 | 12 |
| 8.0 | 3 | M052800108 | 07 |
| 10.0 | 4 | M052800109 | 04 |
| 15.0 | 6 | M052800110 | 02 |
| 20.0 | 8 | M052800111 | 01 |
| 25.0 | 10 | 801-100* | As Req. |
| 30.0 | 12 | 801-120* | As Req. |



* Trading items are in grey colour. SOC-SOCKET

uPVC PRESSURE FITTINGS

SCHEDULE 80 AS PER ASTM D2467

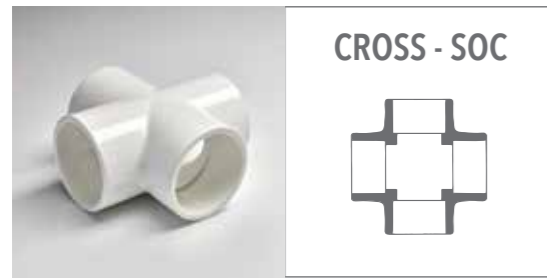

| Size (cm) | Size (inch) | Product Code | Std. Pkg. (Nos.) |
|-----------|-------------|--------------|------------------|
| 1.5 | ½ | *820-005 | As Req. |
| 2.0 | ¾ | M052802402 | 50 |
| 2.5 | 1 | M052802403 | 50 |
| 3.2 | 1¼ | M052802404 | 30 |
| 4.0 | 1½ | M052802405 | 25 |
| 5.0 | 2 | M052802406 | 15 |
| 6.5 | 2½ | M052802407 | 09 |
| 8.0 | 3 | M052802408 | 06 |
| 10.0 | 4 | 820-040* | As Req. |
| 15.0 | 6 | 820-060F* | As Req. |
| 20.0 | 8 | 820-080F* | As Req. |



| Size (cm) | Size (inch) | Product Code | Std. Pkg. (Nos.) |
|-----------|-------------|--------------|------------------|
| 1.5 | ½ | M052801601 | 600 |
| 2.0 | ¾ | M052801602 | 400 |
| 2.5 | 1 | M052801603 | 200 |
| 3.2 | 1¼ | M052801604 | 100 |
| 4.0 | 1½ | M052801605 | 80 |
| 5.0 | 2 | M052801606 | 50 |
| 6.5 | 2½ | M052801607 | 30 |
| 8.0 | 3 | M052801608 | 20 |
| 10.0 | 4 | M052801609 | 12 |
| 15.0 | 6 | 835-060* | As Req. |
| 20.0 | 8 | 835-080* | As Req. |



| Size (cm) | Size (inch) | Product Code | Std. Pkg. (Nos.) |
|-------------|-------------|--------------|------------------|
| 2.0 x 1.5 | ¾ x ½ | M052801114 | 300 |
| 2.5 x 1.5 | 1 x ½ | M052801115 | 250 |
| 2.5 x 2.0 | 1 x ¾ | M052801116 | 200 |
| 3.2 x 1.5 | 1¼ x ½ | M052801117 | 150 |
| 3.2 x 2.0 | 1¼ x ¾ | M052801118 | 140 |
| 3.2 x 2.5 | 1¼ x 1 | M052801119 | 125 |
| 4.0 x 1.5 | 1½ x ½ | M052801120 | 125 |
| 4.0 x 2.0 | 1½ x ¾ | M052801121 | 100 |
| 4.0 x 2.5 | 1½ x 1 | M052801122 | 100 |
| 4.0 x 3.2 | 1½ x 1¼ | M052801123 | 80 |
| 5.0 x 1.5 | 2 x ½ | M052801124 | 70 |
| 5.0 x 2.0 | 2 x ¾ | M052801125 | 70 |
| 5.0 x 2.5 | 2 x 1 | M052801126 | 75 |
| 5.0 x 3.2 | 2 x 1¼ | M052801127 | 60 |
| 5.0 x 4.0 | 2 x 1½ | M052801128 | 50 |
| 6.5 x 3.2 | 2½ x 1¼ | M052801132 | 48 |
| 6.5 x 4.0 | 2½ x 1½ | M052801133 | 40 |
| 6.5 x 5.0 | 2½ x 2 | M052801134 | 40 |
| 8.0 x 4.0 | 3 x 1½ | M052801139 | 27 |
| 8.0 x 5.0 | 3 x 2 | M052801140 | 25 |
| 8.0 x 6.5 | 3 x 2½ | M052801141 | 25 |
| 10.0 x 4.0 | 4 x 1½ | M052801146 | 16 |
| 10.0 x 5.0 | 4 x 2 | M052801147 | 16 |
| 10.0 x 6.5 | 4 x 2½ | M052801148 | 15 |
| 10.0 x 8.0 | 4 x 3 | M052801149 | 15 |
| 15.0 x 5.0 | 6 x 2 | 829-528* | As Req. |
| 15.0 x 6.5 | 6 x 2½ | 829-529* | As Req. |
| 15.0 x 8.0 | 6 x 3 | 829-530* | As Req. |
| 15.0 x 10.0 | 6 x 4 | 829-532* | As Req. |
| 20.0 x 10.0 | 8 x 4 | 829-582* | As Req. |
| 25.0 x 10.0 | 10 x 4 | 829-624F* | As Req. |
| 25.0 x 15.0 | 10 x 6 | 829-626* | As Req. |
| 25.0 x 20.0 | 10 x 8 | 829-628* | As Req. |
| 30.0 x 20.0 | 12 x 8 | 829-668* | As Req. |
| 30.0 x 25.0 | 12 x 10 | 829-670F* | As Req. |



| Size (cm) | Size (inch) | Product Code | Std. Pkg. (Nos.) |
|------------|-------------|--------------|------------------|
| 2.0 x 1.5 | ¾ x ½ | M052800214 | 150 |
| 2.5 x 1.5 | 1 x ½ | M052800215 | 100 |
| 2.5 x 2.0 | 1 x ¾ | M052800216 | 100 |
| 3.2 x 1.5 | 1¼ x ½ | M052800217 | 60 |
| 3.2 x 2.0 | 1¼ x ¾ | M052800218 | 60 |
| 3.2 x 2.5 | 1¼ x 1 | M052800219 | 50 |
| 4.0 x 1.5 | 1½ x ½ | M052800220 | 40 |
| 4.0 x 2.0 | 1½ x ¾ | M052800221 | 40 |
| 4.0 x 2.5 | 1½ x 1 | M052800222 | 40 |
| 4.0 x 3.2 | 1½ x 1¼ | M052800223 | 30 |
| 5.0 x 1.5 | 2 x ½ | M052800224 | 30 |
| 5.0 x 2.0 | 2 x ¾ | M052800225 | 25 |
| 5.0 x 2.5 | 2 x 1 | M052800226 | 20 |
| 5.0 x 3.2 | 2 x 1¼ | M052800227 | 20 |
| 5.0 x 4.0 | 2 x 1½ | M052800228 | 20 |
| 6.5 x 1.5 | 2½ x ½ | A052800229 | As Req. |
| 6.5 x 2.0 | 2½ x ¾ | A052800230 | As Req. |
| 6.5 x 2.5 | 2½ x 1 | M052800231 | 15 |
| 6.5 x 3.2 | 2½ x 1¼ | M052800232 | 15 |
| 6.5 x 4.0 | 2½ x 1½ | M052800233 | 15 |
| 6.5 x 5.0 | 2½ x 2 | M052800234 | 12 |
| 8.0 x 1.5 | 3 x ½ | A052800235 | As Req. |
| 8.0 x 2.0 | 3 x ¾ | A052800236 | As Req. |
| 8.0 x 2.5 | 3 x 1 | M052800237 | 10 |
| 8.0 x 3.2 | 3 x 1¼ | A052800238 | As Req. |
| 8.0 x 4.0 | 3 x 1½ | M052800239 | 10 |
| 8.0 x 5.0 | 3 x 2 | M052800240 | 09 |
| 8.0 x 6.5 | 3 x 2½ | M052800241 | 09 |
| 10.0 x 1.5 | 4 x ½ | A052800242 | As Req. |
| 10.0 x 2.0 | 4 x ¾ | A052800243# | As Req. |
| 10.0 x 2.5 | 4 x 1 | M052800244 | 05 |
| 10.0 x 3.2 | 4 x 1¼ | M052800245 | 05 |
| 10.0 x 4.0 | 4 x 1½ | M052800246 | 05 |
| 10.0 x 5.0 | 4 x 2 | M052800247 | 05 |
| 10.0 x 6.5 | 4 x 2½ | M052800248 | 05 |
| 10.0 x 8.0 | 4 x 3 | M052800249 | 05 |



| Size (cm) | Size (inch) | Product Code | Std. Pkg. (Nos.) |
|-----------|-------------|--------------|------------------|
| 1.5 | ½ | M052801301 | 600 |
| 2.0 | ¾ | M052801302 | 400 |
| 2.5 | 1 | M052801303 | 250 |
| 3.2 | 1¼ | M052801304 | 150 |
| 4.0 | 1½ | M052801305 | 100 |
| 5.0 | 2 | M052801306 | 60 |
| 6.5 | 2½ | M052801307 | 30 |
| 8.0 | 3 | M052801308 | 20 |
| 10.0 | 4 | M052801309 | 15 |
| 15.0 | 6 | 836-060* | As Req. |
| 2.0 x 1.5 | ¾ x ½ | M052801314 | 400 |



| Size (cm) | Size (inch) | Product Code | Std. Pkg. (Nos.) |
|-----------|-------------|--------------|------------------|
| 1.5 | ½ | M052804101 | 800 |
| 2.0 | ¾ | M052804102 | 500 |
| 2.5 | 1 | M052804103 | 300 |
| 3.2 | 1¼ | M052804104 | 150 |
| 4.0 | 1½ | M052804105 | 100 |
| 5.0 | 2 | M052804106 | 60 |
| 6.5 | 2½ | M052804107 | 40 |
| 8.0 | 3 | M052804108 | 25 |
| 10.0 | 4 | M052804109 | 18 |
| 15.0 | 6 | M052804110 | 15 |
| 20.0 | 8 | 847-080* | As Req. |
| 25.0 | 10 | 847-100F* | As Req. |
| 30.0 | 12 | 847-120F* | As Req. |

* Trading items are in grey colour. SOC-SOCKET
Shortly introducing

All the items where product code starts with "F" are fabricated items and code starting with "A" are assembled items.
* Trading items are in grey colour. # Shortly introducing
SOC-SOCKET, SPG-SPIGOT, THD-THREADED

uPVC PRESSURE FITTINGS

SCHEDULE 80 AS PER ASTM D-2467



| Size (cm) | Size (inch) | Product Code | Std. Pkg. (Nos.) |
|-------------|-------------|--------------|------------------|
| 15.0 x 6.5 | 6 x 2½ | M052800256 | As Req. |
| 15.0 x 8.0 | 6 x 3 | M052800257 | 02 |
| 15.0 x 10.0 | 6 x 4 | M052800258 | 02 |
| 20.0 x 15.0 | 8 x 6 | A052800268 | As Req. |



| Size (cm) | Size (inch) | Product Code | Std. Pkg. (Nos.) |
|-------------|-------------|--------------|------------------|
| 2.0 x 1.5 | ¾ x ½ | M052801914 | 300 |
| 2.5 x 1.5 | 1 x ½ | M052801915 | 400 |
| 2.5 x 2.0 | 1 x ¾ | M052801916 | 400 |
| 3.2 x 1.5 | 1¼ x ½ | M052801917 | 250 |
| 3.2 x 2.0 | 1¼ x ¾ | M052801918 | 250 |
| 3.2 x 2.5 | 1¼ x 1 | M052801919 | 250 |
| 4.0 x 1.5 | 1½ x ½ | M052801920 | 150 |
| 4.0 x 2.0 | 1½ x ¾ | M052801921 | 150 |
| 4.0 x 2.5 | 1½ x 1 | M052801922 | 150 |
| 4.0 x 3.2 | 1½ x 1¼ | M052801923 | 150 |
| 5.0 x 1.5 | 2 x ½ | M052801924 | 100 |
| 5.0 x 2.0 | 2 x ¾ | M052801925 | 100 |
| 5.0 x 2.5 | 2 x 1 | M052801926 | 100 |
| 5.0 x 3.2 | 2 x 1¼ | M052801927 | 100 |
| 5.0 x 4.0 | 2 x 1½ | M052801928 | 100 |
| 6.5 x 3.2 | 2½ x 1¼ | M052801932 | 50 |
| 6.5 x 4.0 | 2½ x 1½ | M052801933 | 50 |
| 6.5 x 5.0 | 2½ x 2 | M052801934 | 50 |
| 8.0 x 2.5 | 3 x 1 | A052801937 | As Req. |
| 8.0 x 3.2 | 3 x 1¼ | A052801938 | As Req. |
| 8.0 x 4.0 | 3 x 1½ | M052801939 | 35 |
| 8.0 x 5.0 | 3 x 2 | M052801940 | 35 |
| 8.0 x 6.5 | 3 x 2½ | M052801941 | 35 |
| 10.0 x 5.0 | 4 x 2 | M052801947 | 20 |
| 10.0 x 6.5 | 4 x 2½ | M052801948 | 20 |
| 10.0 x 8.0 | 4 x 3 | M052801949 | 20 |
| 15.0 x 8.0 | 6 x 3 | A052801957 | As Req. |
| 15.0 x 10.0 | 6 x 4 | M052801958 | 06 |
| 20.0 x 15.0 | 8 x 6 | M052801968 | 03 |
| 25.0 x 10.0 | 10 x 4 | 837-624* | As Req. |
| 25.0 x 15.0 | 10 x 6 | 837-626* | As Req. |
| 25.0 x 20.0 | 10 x 8 | 837-628* | As Req. |
| 30.0 x 15.0 | 12 x 6 | 837-666** | As Req. |
| 30.0 x 20.0 | 12 x 8 | 837-668* | As Req. |
| 30.0 x 25.0 | 12 x 10 | 837-670* | As Req. |



| Size (cm) | Size (inch) | Product Code | Std. Pkg. (Nos.) |
|-----------|-------------|--------------|------------------|
| 1.5 | ½ | F052800901 | 120 |
| 2.0 | ¾ | F052800902# | As Req. |
| 2.5 | 1 | F052800903# | As Req. |
| 3.2 | 1¼ | F052800904# | As Req. |
| 4.0 | 1½ | F052800905# | As Req. |
| 5.0 | 2 | F052800906# | As Req. |
| 6.5 | 2½ | F052800907# | As Req. |
| 8.0 | 3 | F052800908# | As Req. |
| 10.0 | 4 | F052800909 | 04 |
| 15.0 | 6 | F052800910 | 01 |



| Size (cm) | Size (inch) | Product Code | Std. Pkg. (Nos.) |
|-----------|-------------|--------------|------------------|
| 1.5 | ½ | M052803301# | As Req. |
| 2.0 | ¾ | M052803302# | As Req. |
| 2.5 | 1 | M052803303# | As Req. |
| 3.2 | 1¼ | M052803304# | As Req. |
| 4.0 | 1½ | M052803305# | As Req. |
| 5.0 | 2 | M052803306# | As Req. |
| 6.5 | 2½ | M052803307# | As Req. |
| 8.0 | 3 | M052803308 | 16 |
| 10.0 | 4 | M052803309 | 06 |
| 15.0 | 6 | 856-060* | As Req. |



| Size (cm) | Size (inch) | Product Code | Std. Pkg. (Nos.) |
|-----------|-------------|--------------|------------------|
| 1.5 | ½ | F052802801# | As Req. |
| 2.0 | ¾ | F052802802# | As Req. |
| 2.5 | 1 | F052802803# | As Req. |
| 3.2 | 1¼ | F052802804# | As Req. |
| 4.0 | 1½ | F052802805# | As Req. |
| 5.0 | 2 | F052802806# | As Req. |



| Size (cm) | Size (inch) | Product Code | Std. Pkg. (Nos.) |
|-----------|-------------|--------------|------------------|
| 8.0 | 3 | M052803208 | 12 |
| 10.0 | 4 | M052803209 | 08 |



| Size (cm) | Size (inch) | Product Code | Std. Pkg. (Nos.) |
|-----------|-------------|--------------|------------------|
| 1.5 | ½ | M052803401 | 120 |
| 2.0 | ¾ | M052803402 | 80 |
| 2.5 | 1 | M052803403 | 60 |
| 3.2 | 1¼ | M052803404 | 50 |
| 4.0 | 1½ | M052803405 | 35 |
| 5.0 | 2 | M052803406 | 25 |
| 6.5 | 2½ | M052803407 | 15 |
| 8.0 | 3 | M052803408 | 12 |
| 10.0 | 4 | M052803409 | 08 |
| 15.0 | 6 | M052803410 | 03 |
| 20.0 | 8 | M052803411 | 01 |
| 25.0 | 10 | 854-100* | As Req. |
| 30.0 | 12 | 854-120* | As Req. |



| Size (cm) | Size (inch) | Product Code | Std. Pkg. (Nos.) |
|-----------|-------------|--------------|------------------|
| 1.5 | ½ | M052803601 | As Req. |
| 2.0 | ¾ | M052803602 | As Req. |
| 2.5 | 1 | M052803603 | As Req. |
| 3.2 | 1¼ | M052803604 | As Req. |
| 4.0 | 1½ | M052803605 | As Req. |
| 5.0 | 2 | M052803606 | As Req. |
| 6.5 | 2½ | M052803607 | As Req. |
| 8.0 | 3 | M052803608 | As Req. |
| 10.0 | 4 | M052803609 | As Req. |
| 15.0 | 6 | M052803610 | As Req. |
| 20.0 | 8 | M052803611 | As Req. |

* Trading Item. SOC-SOCKET # Shortly Introducing
All the items where product code starts with "F" are fabricated items.

Note: Ball Valves rated working pressure is 150 psi (10 kgf/cm²) at 23°C
SOC-SOCKET, SPG-SPIGOT. * Trading Item. # Shortly Introducing

uPVC PRESSURE FITTINGS

SCHEDULE 80 AS PER ASTM D-2467



| Size (cm) | Size (inch) | Product Code | Std. Pkg. (Nos.) |
|-----------|-------------|--------------|------------------|
| 1.5 | ½ | M052802701 | 48 |
| 2.0 | ¾ | M052802702 | 36 |
| 2.5 | 1 | M052802703 | 16 |
| 3.2 | 1¼ | M052802704 | 10 |
| 4.0 | 1½ | M052802705 | 08 |
| 5.0 | 2 | M052802706 | 06 |



| Size (cm) | Size (inch) | Product Code | Std. Pkg. (Nos.) |
|-----------|-------------|--------------|------------------|
| 1.5 | ½ | M052804201 | As Req. |
| 2.0 | ¾ | M052804202 | As Req. |
| 2.5 | 1 | M052804203 | As Req. |
| 3.2 | 1¼ | M052804204 | As Req. |
| 4.0 | 1½ | M052804205 | As Req. |
| 5.0 | 2 | M052804206 | As Req. |
| 6.5 | 2½ | M052804207 | As Req. |
| 8.0 | 3 | M052804208 | As Req. |
| 10.0 | 4 | M052804209 | As Req. |
| 15.0 | 6 | M052804210 | As Req. |
| 20.0 | 8 | M052804211 | As Req. |



| Size (cm) | Size (inch) | Product Code | Std. Pkg. (Nos.) |
|-----------|-------------|--------------|------------------|
| 1.5 | ½ | M052803701# | As Req. |
| 2.0 | ¾ | M052803702# | As Req. |
| 2.5 | 1 | M052803703# | As Req. |
| 3.2 | 1¼ | M052803704# | As Req. |
| 4.0 | 1½ | M052803705# | As Req. |
| 5.0 | 2 | M052803706# | As Req. |
| 6.5 | 2½ | M052803707# | As Req. |
| 8.0 | 3 | M052803708 | As Req. |
| 10.0 | 4 | M052803709 | As Req. |



| Size (cm) | Size (inch) | Product Code | Std. Pkg. (Nos.) |
|-----------|-------------|--------------|------------------|
| 6.5 | 2½ | 853-025* | - |
| 8.0 | 3 | M052803108 | 20 |
| 10.0 | 4 | M052803109 | 12 |
| 15.0 | 6 | 853-060* | - |



| Size (cm) | Size (inch) | Product Code | Std. Pkg. (Nos.) |
|-----------|-------------|--------------|------------------|
| 2.0 | ¾ | M0528012702 | 600 |
| 2.5 | 1 | M0528012703 | 350 |

Note: Ball Valves rated working pressure is 150 psi (10 kgf/cm²) at 23°C
SOC-SOCKET, SPG-SPIGOT * Trading Item. # Shortly Introducing

* Trading Item

uPVC SOLVENT CEMENT & PRIMER



| Qty. (ml) | Product Code | Std. Pkg. (Nos.) |
|-----------|--------------|------------------|
| 50 | TIPS50P705 | 48 |
| 118 | TIPS118P705 | 24 |
| 237 | TIPS237P705 | 24 |
| 473 | TIPS473P705 | 12 |
| 946 | TIPS946P705 | 12 |



| Qty. (ml) | Product Code | Std. Pkg. (Nos.) |
|-----------|--------------|------------------|
| 22.17 | TIPS2217P705 | 48 |
| 44 | TIPS44P705 | 24 |

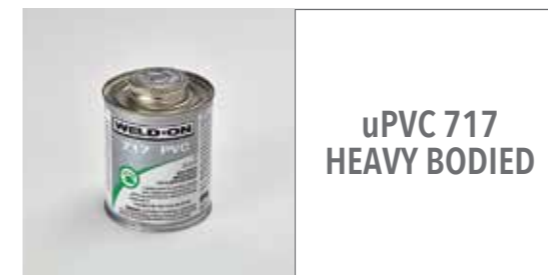

| Qty. (ml) | Product Code | Std. Pkg. (Nos.) |
|-----------|--------------|------------------|
| 473 | TIPS473P717 | 12 |
| 946 | TIPS946P717 | 12 |



| Qty. (ml) | Product Code | Std. Pkg. (Nos.) |
|-----------|--------------|------------------|
| 473 | MIPS473P735 | 12 |
| 946 | MIPS946P735 | 12 |



| Qty. (ml) | Product Code | Std. Pkg. (Nos.) |
|-----------|--------------|------------------|
| 473 | TEZ-221 | 12 |
| 946 | TEZ-220 | 12 |

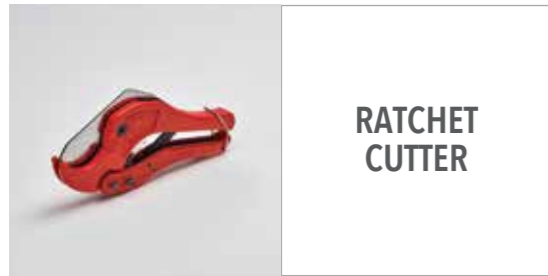

**RATCHET
CUTTER**

| Size (cm) | Size (inch) | Product Code | Std. Pkg. (Nos.) |
|-----------|-------------|--------------|------------------|
| 1.5 - 3.2 | ½ - 1¼ | TTOOLS-1 | As Req. |



PTFE TAPE

| Size (Mtr.) | Product Code | Std. Pkg. (Nos.) |
|-------------|--------------|------------------|
| 5 | PTFE-1205 | As Req. |
| 10 | PTFE-1210 | As Req. |
| 20 | PTFE-1220 | As Req. |

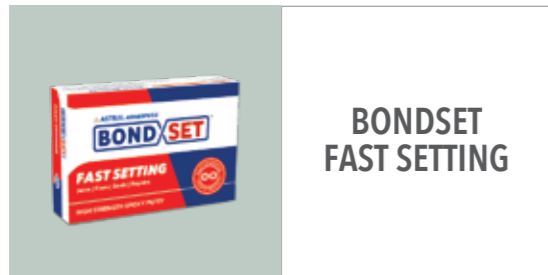

**BONDSET
FAST SETTING**

| Qty. (gm) | Product Code | Std. Pkg. (Nos.) |
|-----------|---------------|------------------|
| 50 | BONDSETFS-50 | As Req. |
| 100 | BONDSETFS-100 | As Req. |

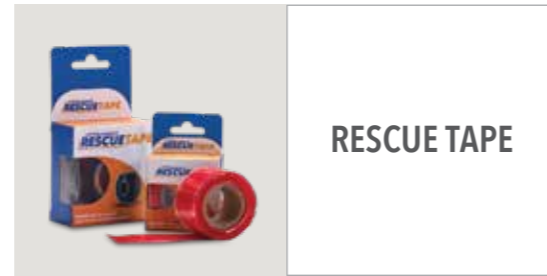

RESCUE TAPE

| Size (Ft.) | Product Code | Std. Pkg. (Nos.) |
|------------|------------------|------------------|
| 5 | RSCU-TAPE-05-CLR | 120 |
| 5 | RSCU-TAPE-05-RED | 120 |
| 5 | RSCU-TAPE-05-BLK | 120 |
| 10 | RSCU-TAPE-10-CLR | 120 |
| 10 | RSCU-TAPE-10-RED | 120 |
| 10 | RSCU-TAPE-10-BLK | 120 |
| 15 | RSCU-TAPE-15-CLR | 120 |
| 15 | RSCU-TAPE-15-RED | 120 |
| 15 | RSCU-TAPE-15-BLK | 120 |



EXPANSION AND CONTRACTION OF uPVC PIPE

CARRYING CAPACITY AND FRICTION LOSS FOR SCHEDULE 80 THERMOPLASTIC PIPE

uPVC pipes, like other piping materials, undergo length changes as a result of temperature variations above and below the installation temperature. They expand and contract 4.5 to 5 times more than steel or iron pipe. The extent of the expansion - contraction depends upon the coefficient of linear expansion of piping material. The length of pipe between directional changes, and the temperature differential.

The coefficient of thermal expansion (Y)

for uPVC is 3.1×10^{-5} in./in./°F.

The amount of expansion and contraction can be calculated using the following formula:

$$\Delta L = Y(T_1 - T_2) \times L$$

ΔL = Dimensional change due to thermal expansion or contraction (Inch)

Y = Expansion coefficient (in./in./°F)

($T_1 - T_2$) = Temperature differential between the installation temperature and the maximum or minimum system temperature, whichever provides the greatest differential (°F).

L = Length of pipe run between changes in direction (ft.).

There are several ways to compensate for expansion and contraction. The most common method are:

1. Expansion loops which consist of pipe and 90° elbows.
2. Piston type expansion joints*
3. Flexible bends*
4. Bellows and rubber expansion joints*

* The manufacturers of these devices should be contacted to determine the suitability of their products for the specific application.

Expansion loops are a simple and convenient way to compensate for expansion and contraction when there is sufficient space for the loop in the piping system. A typical expansion loop design is shown below:

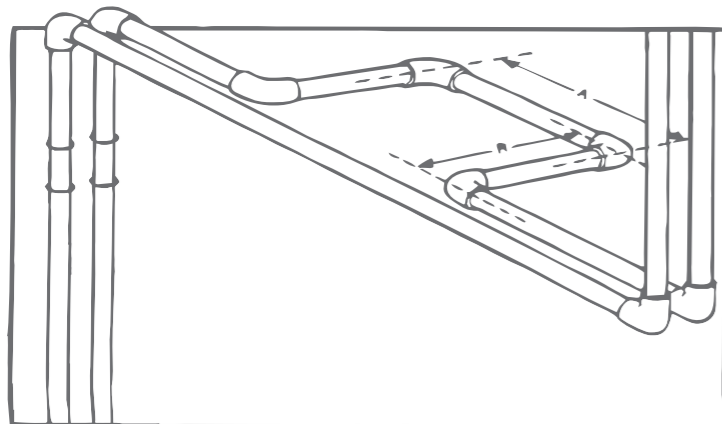

The length of leg "R" can be determined by using the following formula to ensure that it is long enough to absorb the expansion and contraction movement without damage. The length of leg "A" should be 1/2 the length of leg "R"

- R = $1.44 D \Delta L$
- R = Expansion loop leg length (ft)
- D = Nominal outside diameter of pipe (in.) (See table below.)
- ΔL = Dimensional change due to thermal expansion or contraction (in.)

When installing the expansion loop, no rigid or restraining supports should be placed within the leg lengths of the loop. The loop should be installed as closely as possible to the mid-point between anchors. Piping support guides should restrict lateral movement and direct axial movement into the loop. Lastly, the pipe and fittings should be solvent cemented together, rather than using threaded connections.

Compensation for expansion and contraction in underground application is normally achieved by snaking the pipe in the trench. Proper trenching and burial procedures must be followed to protect the piping system.

The table below shows recommended offsets & loop lengths for piping upto 2½ inches nominal sizes.

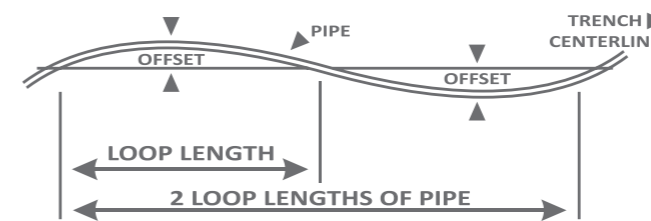

| Loop Offset in Inches | Max. Temp. Variation °F, Between Installation and Final Operation | | | | | | | | | |
|-----------------------|---|------|------|------|------|------|------|------|------|------|
| | 10° | 20° | 30° | 40° | 50° | 60° | 70° | 80° | 90° | 100° |
| 20 | 3.0 | 3.5 | 4.5 | 5.0 | 6.0 | 6.5 | 7.0 | 7.0 | 8.0 | 8.0 |
| 50 | 7.0 | 9.0 | 11.0 | 13.0 | 14.0 | 15.5 | 17.0 | 18.0 | 19.0 | 20.0 |
| 100 | 13.0 | 18.0 | 22.0 | 26.0 | 29.0 | 31.5 | 35.0 | 37.0 | 40.0 | 42.0 |

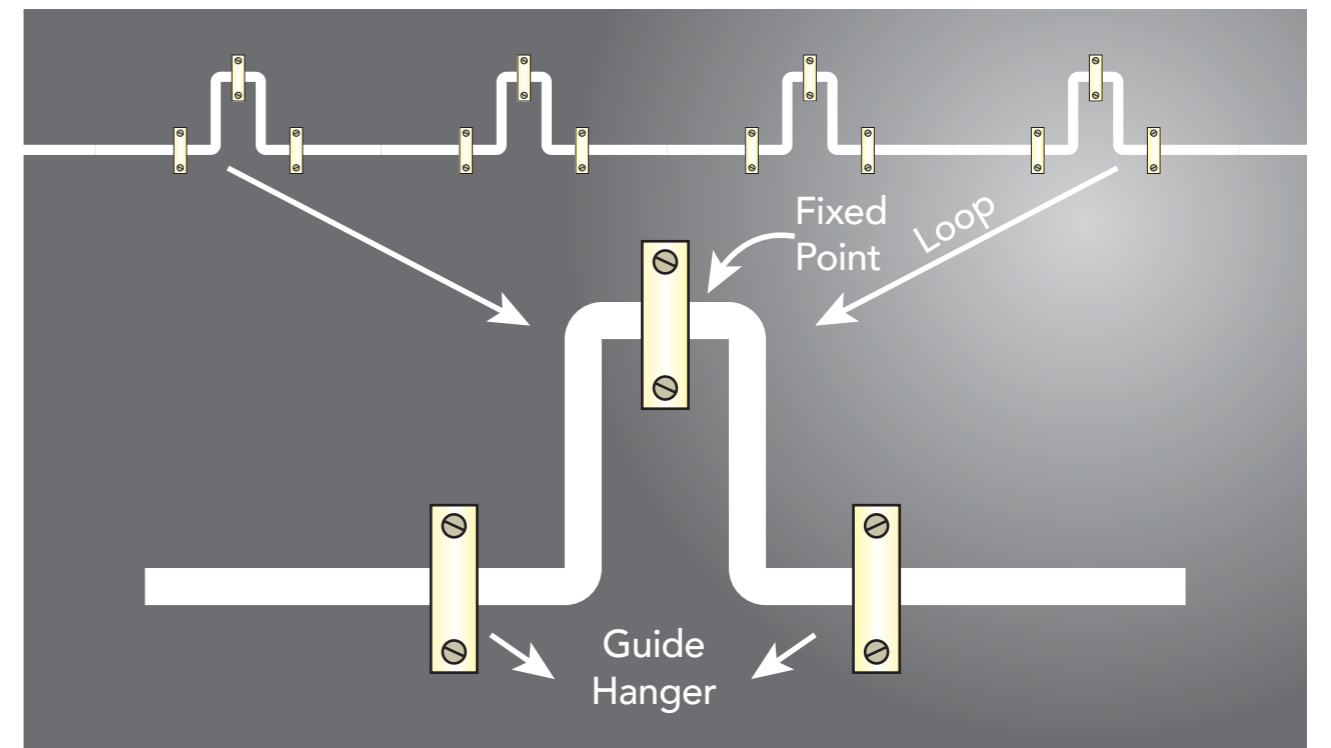

JOINT CURING

RECOMMENDED INITIAL SET TIMES.

| Temperature | Pipe Size | Pipe Size | Pipe Size | Pipe Size |
|-----------------|-------------|-------------|---------------|---------------|
| Range | ½" to 1¼" | ½" to 3" | 4" to 8" | 10" to 12" |
| | 15 to 32 mm | 40 to 80 mm | 100 to 200 mm | 250 to 300 mm |
| 15.5°C - 37.7°C | 15 min. | 30 min. | 1 hr. | 2 hr. |
| 4.4°C - 15.5°C | 1 hr. | 2 hrs. | 4 hrs. | 8 hrs. |

RECOMMENDED INITIAL SET TIMES.

| Temperature | Pipe Size | Pipe Size | Pipe Size | Pipe Size |
|-----------------|-------------|-------------|---------------|---------------|
| Range | ½" to 1¼" | ½" to 3" | 4" to 8" | 10" to 12" |
| | 15 to 32 mm | 40 to 80 mm | 100 to 200 mm | 250 to 300 mm |
| 15.5°C - 37.7°C | 6 hrs. | 12 hrs. | 24 hr. | 48 hr. |
| 4.4°C - 15.5°C | 12 hr. | 24 hrs. | 48 hrs. | 96 hrs. |

SUPPORT SPACING FOR uPVC PIPE

Adequate supports for any piping system is a matter of great importance. In practice, support spacings are a function of pipe size operating temperatures, the location of heavy valves or fittings and the mechanical properties of the pipe material. To ensure the satisfactory operation of a ASTRAL Aquarius uPVC piping system, the location and type of hangers should be carefully considered. Hangers should not compress, distort, cut or abrade the piping.

All piping should be supported with an approved hanger at intervals sufficiently close to maintain correct pipe alignment and to prevent sagging or reversal. Pipe should also be supported at all branch ends and at all changes of direction. Support trap arms as close as possible to the trap. In keeping with good plumbing practices support and brace all closet bends and fasten closet angles.

1. Concentrated loads should be supported directly so as to eliminate high stress concentrations. Should this be impractical then the pipe must be supported immediately adjacent to the load.
2. In systems where large fluctuations in temperature occur, allowances must be made for expansion and contraction of the piping system. Since changes in direction in the system are usually sufficient to allow for expansion and contraction hangers must be placed so as not to restrict this movement.
3. Since plastic pipe expands or contracts approximately five times greater than those of steel, hangers should not restrict this movement.
4. Hangers should provide as much bearing surface as possible. To prevent damage to the pipe, file smooth any sharp edges or burrs on the hangers or supports.
5. Support spacing for horizontal piping systems is determined by the maximum operating temperature the system will encounter. The piping should be supported on uniform centers with supports that do not restrict the axial movement.
6. For vertical lines, it is recommended that an engineer should design the vertical supports according to the vertical load involved.



SCHEDULE - 40 RECOMMENDED SUPPORT SPACING (IN FEET)

| Nom. Pipe Size (in.) | Nom. Pipe Size (mm) | Temperature °C | | | | |
|----------------------|---------------------|----------------|------|------|------|----|
| | | 15.5 | 26.6 | 37.7 | 48.8 | 60 |
| - | - | 15.5 | 26.6 | 37.7 | 48.8 | 60 |
| ½ | 15 | 4½ | 4½ | 4 | 2½ | 2½ |
| ¾ | 20 | 5 | 4½ | 4 | 2½ | 2½ |
| 1 | 25 | 5½ | 5 | 4½ | 3 | 2½ |
| 1¼ | 32 | 5½ | 5½ | 5 | 3 | 3 |
| 1½ | 40 | 6 | 5½ | 5 | 3½ | 3 |
| 2 | 50 | 6 | 5½ | 5 | 3½ | 3 |
| 2½ | 65 | 6½ | 6 | 5½ | 4 | 3 |
| 3 | 80 | 7 | 7 | 6 | 4 | 3½ |
| 4 | 100 | 7½ | 7 | 6½ | 4½ | 4 |
| 6 | 150 | 8½ | 8 | 7½ | 5 | 4½ |
| 8 | 200 | 9½ | 9 | 8½ | 5½ | 5 |
| 10 | 250 | 10½ | 9½ | 9 | 6½ | 5½ |
| 12 | 300 | 12 | 10½ | 9½ | 7 | 6 |

SCHEDULE - 80 RECOMMENDED SUPPORT SPACING (IN FEET)

| Nom. Pipe Size (in.) | Nom. Pipe Size (mm) | Temperature °C | | | | |
|----------------------|---------------------|----------------|------|------|------|----|
| | | 15.5 | 26.6 | 37.7 | 48.8 | 60 |
| - | - | 15.5 | 26.6 | 37.7 | 48.8 | 60 |
| ½ | 15 | 5 | 4½ | 4½ | 3 | 2½ |
| ¾ | 20 | 5½ | 5 | 4½ | 3 | 2½ |
| 1 | 25 | 6 | 5½ | 5 | 3½ | 3 |
| 1¼ | 32 | 6 | 6 | 5½ | 3½ | 3 |
| 1½ | 40 | 6½ | 6 | 5½ | 3½ | 3½ |
| 2 | 50 | 7 | 6½ | 6 | 4 | 3½ |
| 2½ | 65 | 7½ | 7½ | 6½ | 4½ | 4 |
| 3 | 80 | 8 | 7½ | 7 | 4½ | 4 |
| 4 | 100 | 9 | 8½ | 7½ | 5 | 4½ |
| 6 | 150 | 10 | 9½ | 8½ | 6½ | 5½ |
| 8 | 200 | 11 | 10 | 9½ | 7½ | 6 |
| 10 | 250 | 12½ | 11 | 10½ | 7½ | 6½ |
| 12 | 300 | 13 | 12 | 10½ | 7½ | 6½ |

INSTALLATION PROCEDURE



1. CUT PIPE

- Cut pipe square. As joints are sealed at the base of the fitting socket. An angled cut may result in joint failure.
- Acceptable tools include miter saw, mechanical cut off saw or wheel cutter. Wheel type cutters must employ a blade designed for plastics.



2. REMOVE BURR & BEVEL

- Remove all burr from inside and outside of pipe with a knife-edge, file or deburring tool. Chamfer (bevel) the end of the pipe 10° -15°.
- Remove surface dirt, grease or moisture with a clean dry cloth.



3. DRY FIT

- With light pressure, pipe should go one third to one half of the way into the fitting socket. Pipes and Fittings that are too tight or too loose should not be used.



4. APPLICATOR

- Use an applicator that is one half the pipe diameter.
- Too large an applicator will force excessive cement into the inside of small diameter fittings. Too small an applicator will not apply sufficient cement to large diameter systems.

5. CEMENT

- Apply a full even layer of cement to the outside of a pipe and medium layer of cement to the inside of a fitting.



6. JOIN PIPE & FITTING

- Assemble pipe and fitting socket till it contacts socket bottom. Give pipe a quarter turn. Hold pipe and fitting together until the pipe does not back out.
- Remove excessive cement from the exterior. A properly made joint will show a continuous bead of cement around the perimeter.
- Observe all safety precautions.
- System should be installed in a good and workman like manner consistent with normal industry standards and in conformance with all local plumbing, fire and building code requirements. Failure to follow proper installation practices, procedures or techniques can result in system failure, property damage or personal injury.
- Pipes and fittings should be used for their intended purpose as defined by local plumbing and building codes and the applicable ASTM standards.
- Follow manufacturers instructions for all related products.



uPVC CEMENT FOR SCH 40 AND INTERFERENCE FIT

| Pipe Size (in.) (mm) | Cement Type | Min. Vis. (cP) | IPS-Weld On |
|----------------------|---------------|----------------|-------------|
| (1/2-2) (15-50) | Medium Bodied | 500 | 705 |
| (2 1/2-12) (65-300) | Heavy Bodied | 1600 | 717 |

uPVC CEMENT FOR SCH 80 AND INTERFERENCE FIT

| Pipe Size (in.) (mm) | Cement Type | Min. Vis. (cP) | IPS-Weld On |
|----------------------|---------------|----------------|-------------|
| (1/2-2) (15-50) | Medium Bodied | 500 | 705 |
| (1 1/2-12) (40-300) | Heavy Bodied | 1600 | 717 |

TESTING PRESSURE SYSTEM

- Prior to testing, safety precautions should be instituted to protect personnel and property in case of test failure.
- Conduct pressure testing with water. DO NOT USE AIR OR OTHER GASES for pressure testing.
- The piping system should be adequately anchored to limit movement. Water under pressure exerts thrust forces in piping systems. Thrust blocking should be provided at changes of direction, change in size and at dead ends.
- Please refer tables given for initial set & cure times before pressure testing.
- The piping systems should be slowly filled with water, taking care to prevent surge and air entrapment. The flow velocity should not exceed 5 feet per second.
- All trapped air must be slowly released. Vents must be provided at all high points of the piping system. All valves and air relief mechanisms should be opened so that the air can be vented while the system is extremely dangerous and it must be slowly and completely vented prior to testing. For sizes 4" & above, ASTRAL recommends to use automatic air relief valves at every 300-400ft. distance & at furthest & highest points of pipeline to avoid any damage to the piping system.

- The piping system can be pressurized to 125% of its designed working pressure. However care must be taken to ensure the pressure does not exceed the working pressure of the lowest rated component in the system (valves, unions, flanges, threaded parts etc.)
- The pressure test should not exceed one hour Any leaking joints or pipe must be cut out and replaced and the line recharged and retested using the same procedure.



UNDERGROUND INSTALLATION

uPVC pipes and fittings can be installed underground, Since these piping systems are flexible systems, proper attention should be given to burial conditions. The stiffness of the piping system is affected by sidewall support, soil compaction, and the condition of the trench, Trench bottoms should be smooth and regular in either undisturbed soil or a layer of compacted backfill. Pipe must lie evenly on this surface throughout the entire length of its barrel, Excavation, bedding and backfill should be in accordance with the provision of the local Plumbing Code having jurisdiction

TRENCHING

The following trenching and burial procedures should be used to protect the piping system.

1. The trench should be excavated to ensure the sides will be stable under all working conditions. The trench should be wide enough to provide adequate room for the following :
 - A. Joining the pipe in the trench.
 - B. Snaking the pipe from side or side to compensate for expansion and contraction.
 - C. Filling and compacting the side fills.The space between the pipe and trench wall must be wider than the compaction equipment used in the compaction of the backfill. Minimum width shall not be less than the greater of either the pipe outside diameter plus 16 inches or the pipe outside diameter times 1.25 plus 12 inches. Trench width may be different if approved by the design engineer.
2. The trench bottom should be smooth, free of rocks and debris, continuous, and provide uniform support. If ledge rock, hardpan or large boulders are encountered, the trench bottom should be padded with bedding of compacted granular material to a thickness of at least 4 inches. Foundation bedding should be installed as required by the engineer.
3. Trench depth is determined by the pipe's service requirements. Plastic pipe should always be installed at least below the frost level. The minimum cover for lines subject to heavy overhead traffic is 24 inches.
4. A smooth, trench bottom is necessary to support the pipe over its entire length on firm stable material. Blocking should be used charge pipe grade or to intermittently support pipe over low sections in the trench.



HANDLING AND STORAGE

BEDDING AND BACKFILLING

1. Even though sub-soil conditions vary widely from place to place, the pipe backfill should be stable and provide protection for the pipe.
2. The pipe should be surrounded with a granular material which is easily worked around the sides of the pipe. Backfilling should be performed in layer of 6 inch with each layer being sufficiently compacted to 85% to 95% compaction.
3. A mechanical tamper is recommended for compacting sand and gravel backfill which contain a significant proportion of fine grained material, such as silt and clay. If a tamper is not available, compacting should be done by hand.
4. The trench should be completely filled. The back fill should be placed and spread in fairly uniform layers to prevent any unfilled spaces or voids. Large rocks, stones, frozen clods, or other large debris should be removed. Heavy tampers or rolling equipment should only be used to consolidate only the final backfill.

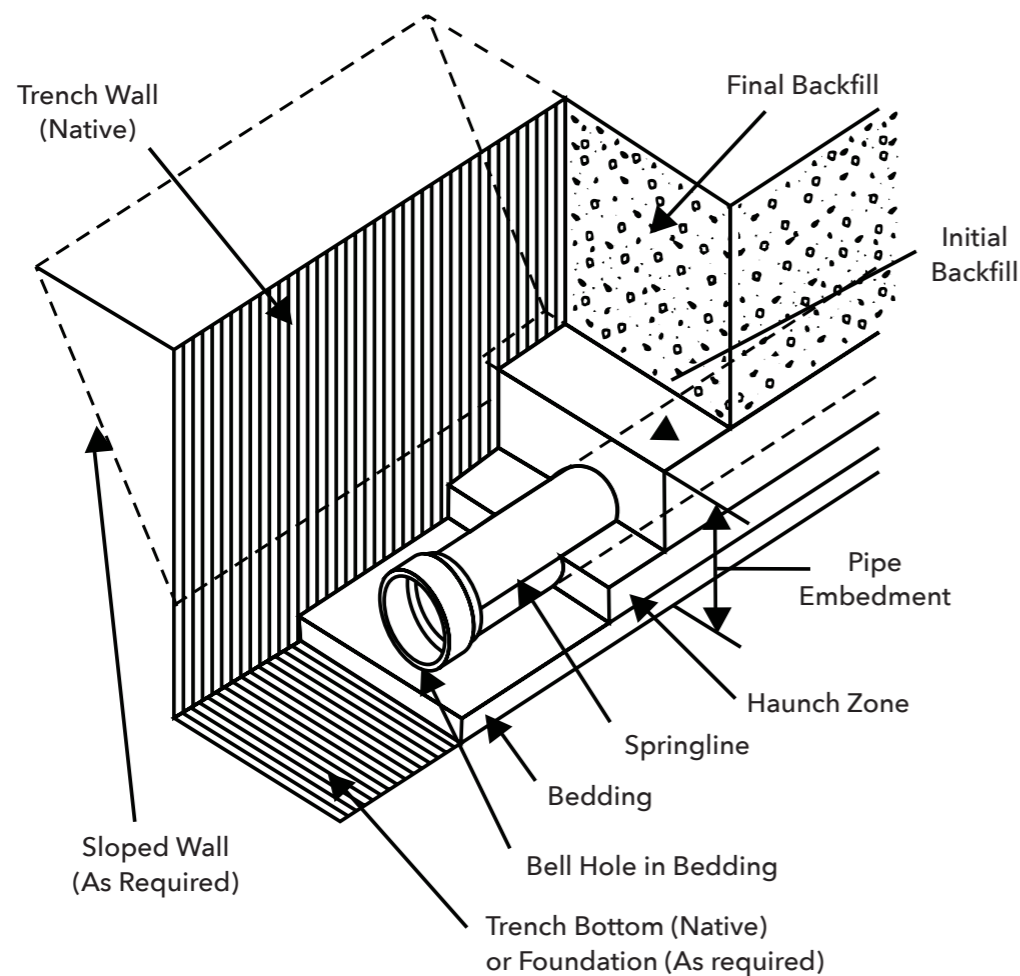

FIG. 1 Installation Terminology

HANDLING

The pipe should be handled with reasonable care. Because thermoplastic pipe is much lighter in weight than metal pipe, there is sometimes a tendency to throw it around. This should be avoided. The pipe should never be dragged or pushed from a truck bed. Pallets of the pipe should be removed with a fork lift. Loose pipe can be rolled down, as long as the pieces do not fall on each other or on any hard or uneven surface. In all cases, severe contact with any sharp objects (rocks, angle irons, forks on forklifts, etc.) should be avoided.

STORAGE

If possible, pipe should be stored inside. When this is not possible, the pipe should be stored on level ground which is dry and free from sharp objects. If different schedules of pipes are stacked together, the pipe with the thickest wall should be at the bottom.

The pipe should be protected from the sun and be in an area with proper ventilation. This will lessen the effects of ultraviolet rays and help prevent heat built-up.

If the pipe is stored in racks, it should be continuously supported along its length. If this is not possible, the spacing of the supports should not exceed three feet (3').

When storage temperatures are below 0°C (32°F), extra care should be taken when handling the pipe. This will help prevent any problems which could be caused by the slightly lower impact strength of uPVC pipe at temperature below freezing point.

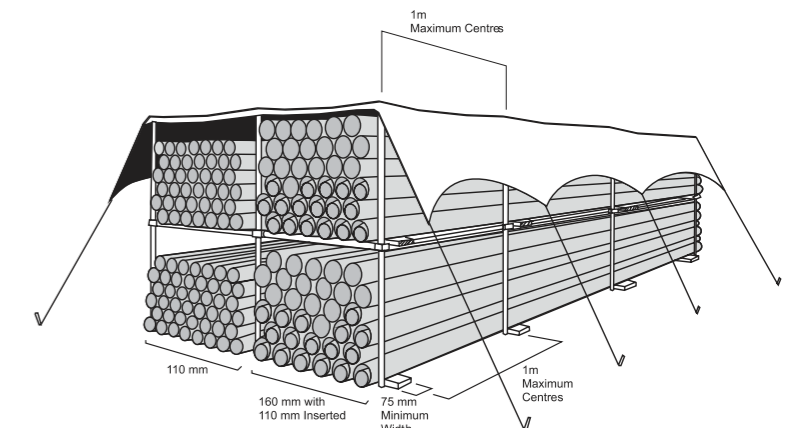

NOT FOR USE WITH COMPRESSED AIR OR GASES

ASTRAL POLY TECHNIK LTD. DOES NOT RECOMMEND the use of thermoplastic piping products for systems to transport or store compressed air or gases, or the testing of thermoplastic piping systems with compressed air or gases in above as well as below ground locations, The use of ASTRAL Aquarius product in compressed air or gas systems automatically void any warranty for such products and its use against our recommendation is entirely the responsibility and liability of the installer.

WARNING: Do not use compressed air or gas to test any PVC thermoplastic piping product or system, and do not use devices propelled by compressed air or gas to clear systems. These practices may result in explosive fragmentation of system piping components causing serious or fatal bodily injury.

FREQUENTLY ASKED QUESTIONS (FAQs)

WHY LEAD-FREE?

Lead is a metal with no known biological benefit to humans. Too much lead can damage various systems of the body including the nervous and reproductive systems and the kidneys, and it can cause high blood pressure and anemia. Lead accumulates in the bones and lead poisoning may be diagnosed from a blue line around the gums. Lead is especially harmful to the developing brains of fetuses and young children and to pregnant women. Lead interferes with the metabolism of calcium and Vitamin D. High blood lead levels in children can cause consequences which may be irreversible including learning disabilities, behavioral problems, and mental retardation. At very high levels, lead can cause convulsions, coma and death. Lead can be dissolved in water when lead pipes are used for transportation of water. So use of such pipes may be harmful to human being. Hence lead free plumbing system is most favoured for potable water transportation.

WHAT IS THE EXPECTED LIFE OF ASTRAL AQUARIUS SYSTEM?

ASTRAL Aquarius uPVC system design & standards incorporate significant engineering safety factors which should translate to a long service life. ASTRAL Aquarius system have a design service life span of 50 years. ASTRAL Aquarius system is not susceptible to corrosion, scale build up or electrolysis in areas where water, solid and / or atmospheric conditions are aggressive. ASTRAL firmly believes that the system will provide a service life as long or longer than alternative materials in the market.

WILL ASTRAL AQUARIUS SYSTEM SAVE MY MONEY?

Yes, as a professional, you will quickly realize that uPVC can be installed at least 25% more quickly than metal systems. Financial savings are also realized with regard to lower tool costs and insurance advantage. Even considering the frequent rise and fall of the metal price structure, uPVC offers a continuing material cost advantage, as much as a full 50-60% material savings today.

WILL ASTRAL AQUARIUS SYSTEM OFFER A FINANCIAL ADVANTAGE TO OWNERS IN TERMS OF UTILITIES EXPENSE?

Yes, the thermal conductivity of a metal system is 2500 times that of a uPVC system. The improved insulating characteristics associated with uPVC can generate long term saving for energy conscious homeowner or tenant. ASTRAL Aquarius will hold the temperature of water for a much longer period of time than metal tubing.

MUST I USE PLASTIC INSULATORS WHEREVER uPVC PASSES THROUGH A STUD?

Technically, no such provision need to be made when passing through wood stud. When passing through metal studs some form of protection must be used to protect the pipe from abrasion and to prevent noise. This protection may come from plastic insulated rubber grommets, pipe insulation or similar.

SHOULD SPECIFIC TYPE OF PRIMERS AND SOLVENT CEMENTS BE USED ON uPVC SYSTEM?

ASTRAL always recommends use of solvent cement which is specifically manufactured to meet the requirements of ASTM D 2564. All purpose solvent cement should not be utilized. Primers manufactured for uPVC pipe is acceptable. For more details, refer installation procedure of this manual.

I HAVE BEEN TOLD THAT UPVC PIPING ENDS MAY SPLIT DURING INSTALLATION. WHY DOES THIS OCCUR? HOW CAN THESE CRACKS BE PREVENTED?

Most cracks are initiated by rough handling. This handling can occur during transportation, while being inventoried at the wholesaler, or while at the job sight. Also, Fine cracks can be caused by cutting the pipe with dull or damaged ratchet cutters. The vast majority cracks occur during colder weather months when temperature is below 10°C, uPVC

like most other plastics such as PP, PEX, CPVC, may become somewhat brittle and should be handled more carefully. To reduce problems resulting from cracked product, several measures can be initiated : (A) Educate your installers. Make them aware of the potential problems and instruct them to handle uPVC in a appropriate way. (B) Use a saw or a circular tubing cutter with a plastic tubing blade to cut your pipe to length. (C) Inspect pipe ends thoroughly prior to making a joint.

Should a crack be evident, cut off any split portion before proceeding. (D) During cold weather, gripping the pipe surrounding the area to be cut for about 10 seconds prior to making the cut will warm the pipe and reduce possible problems.

WHAT ABOUT HEALTH, SAFETY & FIRE TOXICITY ISSUES?

Tests performed at respected universities and independent laboratories confirm that uPVC is superior to metal systems in terms of water quality effects and "no more toxic than wood" in fire. ASTRAL Aquarius uPVC system is manufactured from a compound which is lead free and hence most favoured system in terms of health and safety. LOI of uPVC is 45, which means uPVC is not reality burnable in atmosphere. Once the burning source is removed, It stops burning.

IS ASTRAL AQUARIUS SYSTEM RESISTANT TO U.V. EXPOSURE?

Effect of U.V. on polymers: U.V. acts as a strong catalyst for the oxidations process which breaks down the polymer chains, leading weakness in the pipes & fittings and to loss of hydrostatic strength. "Above effect is very much possible with materials like PP & PE. But for uPVC main process is dehydrochlorination and not oxidation. This dehydrochlorination does not break down the polymer chains to any significant extent after outdoor exposure, being mainly limited to a surface discoloration effect only. There is a loss of impact resistance due to impact modifiers losing their efficiency. This may even result in increased modulus. There is no significant loss in stress bearing capacity impact resistance mainly an installation issue (before any U.V. exposure). Still if a portion of the piping system will be left exposed to U.V. light, a standard grade of exterior, latex paint (water base) will protect the pipe adequately.

IS IT POSSIBLE TO USE ASTRAL AQUARIUS SYSTEM AT TEMPERATURE AROUND 10-15°C?

Practically, Yes. It is very much possible to use ASTRAL Aquarius at a temperature around 10-15°C. Normal temperature range of uPVC compound material is 23°C to 60°C. As temperature decrease beyond 23°C, uPVC becomes brittle like any other thermoplastic material. So it's impact properties decreases as temperature decreases but there is no reduction in hydrostatic strength of material at lower temperatures, So it can be used at lower temperatures but very sound engineering design considerations required at a such low temperatures to eliminate water hammers & impact issues.

WHAT ABOUT THE NOISE EMISSIONS COMPARE TO METALLIC SYSTEM?

The tendency of sound is to travel in the material with fastest possible velocity. This means in the metal system, the sound travels because the velocity of sound in metal is higher than that of in water and create noise emissions. While in uPVC system, noise will travel in water because the velocity of sound in water is higher than that of in uPVC. So uPVC systems are as quiet as physically possible.

WHAT ABOUT SCALE BUILD UP?

Scale built up is a function of the roughness of the pipe, as measured by the Hazen - Williams, "C" factor, used in the Hazen Williams formula for calculating friction head losses in piping system.

Higher value for C results in - less friction, less head loss. In metal systems, once corrosion starts, "C" factor will greatly reduce which results in head loss and scale built up. With ASTRAL Aquarius uPVC, there is no corrosion and hence scale built up is inhibited.

IS IT POSSIBLE TO CONNECT IPS SYSTEM WITH CTS SYSTEM?

IPS (Iron Pipe Size) & CTS (Copper Tube Size) are most widely used systems in plumbing market. Therefore changeability of one to another is very important. ASTRAL has understood this requirement of market and hence developed special transition fittings. These fittings will connect the IPS System (SCH 40 & SCH 80) to CTS system (SDR 11 & SDR 13.5). These transition fittings are joined with one step solvent cement, which gives customer a very fast, efficient & simple solution to join both systems. Available sizes are from 15 mm (½") to 50 mm (2").

